

CRACK MITIGATION AND EVALUATION¹

Shortening of Post-Tensioned Members and Restraint of Supports

Bijan O Aalami²

CONTENTS

Q.1 OVERVIEW

Q.2 COMPUTATION OF SHORTENING

Q.2.2 Shortening from Shrinkage

Q.2.3 Shortening from Creep

Q.2.4 Elastic Shortening

Q.2.5 Temperature Effects

Q.2.6 Shortening Example

Q.2.7 Estimate of Short-Term Shortening

Q.2.8 Short-Term Shortening Example

Q.3 MITIGATION OF RESTRAINT CRACKS

Q.3.1 Assumptions and Overview

Q.3.2 Characteristics of Restraint Cracks

Q.3.3 Crack Mitigation Options;

Q.3.3.1 Favorable Layout

Q.3.3.2 Structural Separation

Q.3.3.3 Delay (Closure) Strips; Joints; Favorable Pour Sequence

Q.3.3.4 Permanent Released Connections

Q.3.3.5 Other Released Connections

Q.3.3.6 Detailing

Q.4 CRACK MITIGATION EXAMPLES

Q.4.1 Podium Slab on Perimeter Walls

Q.4.2 Example of a Multistory Building

R.1 IMPACT OF SUPPORT RESTRAINT ON FLOOR SAFETY

R.1.1 Restraint Cracks and Safety

R.1.2 Unbonded Tendons; Safety and Restraint Cracks

R.1.3 Bonded Tendons; Safety and Restraint Cracks

R.2 COMPARISON BETWEEN UNBONDED AND BONDED SYSTEMS

¹ Copyright Bijan O. Aalami, 2015; bjan@PT-Structures.com; www.PT-Structures.com

² Professor Emeritus, San Francisco State University; Principal, ADAPT Corporation; www.adaptsoft.com



Q.6 REPAIR OF RESTRAINT CRACKS

Q.6.1. Crack Evaluation

Q.6.2. Cracks to Repair

Q.6.3. Time of Repair

Q.6.4. Method of Repair

Q.7 REFERENCES

Q.8 NOTATIONS

Q.1 OVERVIEW

In post-tensioned construction, the tendons are stressed and anchored after the concrete member they are embedded in has developed sufficient strength (Fig. Q.1-1a). The tension in the tendons results in an equivalent compression in the concrete, which causes the member to shorten (Fig. Q.1-1b). In most applications, the tendons are profiled so that they also exert a vertical force on the member (Fig. Q.1-1c). The vertical force results in a bending moment in the member; the tendon profile is usually selected to counteract the bending of the member under selfweight, thus reducing the bending under normal loading. This Technical Note deals with the shortening of a post-tensioned member caused by the precompression; the possible restraint of the member's supports to shortening; the possibility of crack formation in the member from this restraint; and finally the evaluation of restraint cracks.

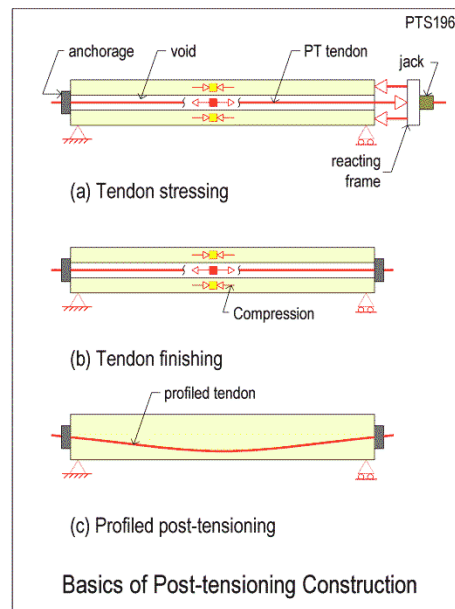

FIGURE Q.1-1 Basics of Post-Tensioning Construction

Because concrete is not a completely rigid material, the post-tensioning force P will compress a free-standing concrete member, and shorten it. The compressive stress f resulting in the member from the application of the force P leads to the member's shortening u . The relationship between the compressive stress in the member and its shortening is governed by the material properties of the member and is generally similar to Fig. Q.1-2a .

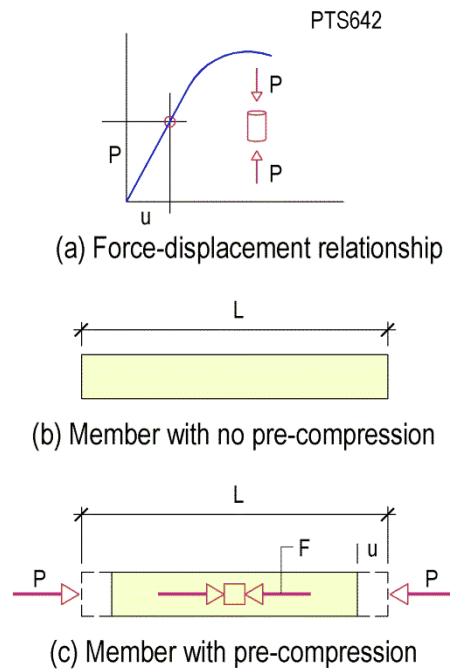

FIGURE Q.1-2 Precompression and Shortening

In actual construction, post-tensioned members such as floor slabs and beams are supported on walls and columns. These supports can restrain the free shortening of the member when the tendons are stressed. Unless the member is allowed to shorten, as shown in Fig. Q.1-3, it will not receive the full amount of precompression from the stressed tendons. In theory, if the supports prevent any shortening (part b of the figure), the entire post-tensioning force will be diverted to the supports, leaving the member with no precompression. Failure to account for restraint from the supports can lead to cracking. Apart from possible aesthetic objections, these restraint cracks can cause leakage, and expose the reinforcement to the corrosive elements. More importantly, restraint cracks can reduce the contribution of the post-tensioning tendons to the strength capacity of the member.

The extent of the restraint cracking in a post-tensioned member depends on a number of factors, including the stiffness of the supports. Figure Q.1-4 illustrates two extremes. In part (a) a post-tensioned member on very flexible supports shortens under the precompression, forcing the supports to follow the member's moment. This can result in cracking of the supports. At the other extreme, a member on very stiff supports will be restrained against in-plane shortening and can develop restraint cracks as it shortens (part b of the figure).

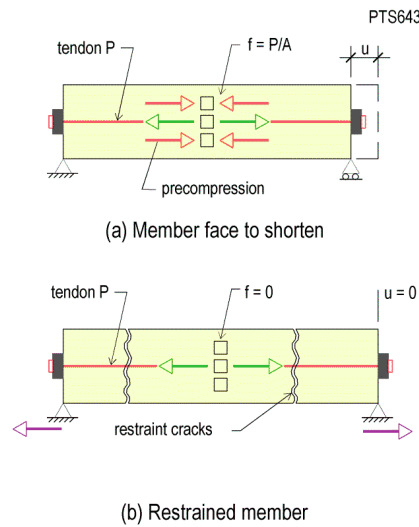

FIGURE Q.1-3 Restrained and Unrestrained Members

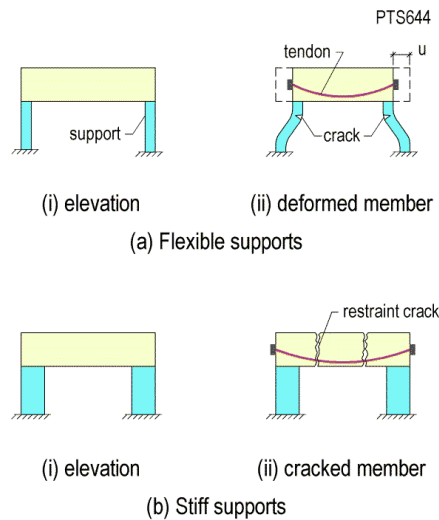

FIGURE Q.1.4 Effects of Support Restraint on Member Cracking

Cracking due to restraint from the supports is generally most pronounced at the first level of a structure, due to the restraint from the foundation; there is less cracking at higher levels. Experienced design engineers are aware of the possibility of restraint cracking and its consequences; they use a number of measures to allow the post-tensioned member to shorten, while minimizing the effects of cracking in either the member or its supports.

The first step in designing for shortening and restraint cracking of a post-tensioned member is to either calculate or estimate the anticipated long-term shortening. Section Q.2 outlines a computational procedure to determine the long-term shortening of a post-tensioned member. Section Q.3 discusses the details commonly used to reduce the potential for restraint cracking. Section Q.4 provides a guideline to estimate shortening for preliminary design and goes through two examples that illustrate the practical aspects of design for crack mitigation. Section Q.5 describes the consequences of restraint cracks on the safety of a post-tensioned member and highlights the significance of the type of post-tensioning (bonded or unbonded).

Q.2 COMPUTATION OF SHORTENING

The long-term shortening of a post-tensioned member is primarily the result of:

- ❖ Shrinkage;
- ❖ Creep;
- ❖ Elastic shortening; and
- ❖ Temperature change.

Much is available in the literature on the contribution of each of the above parameters and the interactions among them. Most of the literature on shortening of concrete members is based on test specimens observed in the controlled environment of research laboratories. The environment of an actual structure will not match that of these test specimens, however. While it is possible to estimate shortening by taking a test specimen from the concrete of the actual structure and curing it in the same environment as the structure, this is not often done. Testing would provide useful data for other structures under the same conditions but would not help with design of the structure being tested. The typical practice is to start with the base values observed in the laboratory specimen and adjust them to reflect the conditions of the actual structure. The adjustment is done by applying various correction factors, each of which accounts for one of the variations between the environment of the actual structure and the environment of the standard test specimen.

Much is available in the literature on the contribution of each of the above parameters and the interactions among them. Most of the literature on shortening of concrete members is based on test specimens observed in the controlled environment of research laboratories. The environment of an actual structure will not match that of these test specimens, however. While it is possible to estimate shortening by taking a test specimen from the concrete of the actual structure and curing it in the same environment as the structure, this is not often done. Testing would provide useful data for other structures under the same conditions but would not help with design of the structure being tested. The typical practice is to start with the base values observed in the laboratory specimen and adjust them to reflect the conditions of the actual structure. The adjustment is done by applying various correction factors, each of which accounts for one of the variations between the environment of the actual structure and the environment of the standard test specimen.

- ❖ The effects of each of the shortening components are independent from one another and can be estimated on their own.
- ❖ The parameters of the structure are within the applicable range of the suggested correction factors. These are:
 - Concrete weight: $W = 140 - 155$ pcf (2300 - 2600 kg/m³)
 - Concrete strength (28 day cylinder): $f'_c = 3000$ to 6000 psi (21 to 40 MPa)
 - Average precompression: $P/A = 100$ to 350 psi (0.8 to 2.40 MPa)

The total shortening of a post-tensioned member meeting the above criteria can be expressed as follows:

$$a = L (ES + SH + CR + TEM) \quad (\text{Exp Q.2-1})$$

Where,

- a = total shortening;
- CR = creep shortening strain;

ES = elastic shortening strain;
 L = length of the member; and
 SH = shrinkage shortening strain; and
 TEM = strain due to drop in temperature.

The creep and shrinkage values obtained through laboratory tests are referred to as the “base shrinkage strain” SH_0 and “base creep coefficient” CR_0 . Strain is a dimensionless quantity, with units of length/length (inch/inch or mm/mm). Because strains are typically quite small, they are usually measured in micro-strains, where a micro-strain is a strain of 1×10^{-6} .

The base shrinkage strain reflects the total reduction in length over the original length of the concrete specimen if the specimen is allowed to freely shorten over an infinite length of time, under constant pre-defined ambient conditions. The base creep coefficient is the ratio of the long-term shortening to the elastic shortening of a concrete specimen that is loaded at a given age and allowed to shorten without restraint under controlled ambient conditions.

Q.2.1 Shortening from Shrinkage

Shrinkage is caused by the loss of moisture from the concrete and is independent of applied stress. In most cases, shrinkage is the largest contributor to floor shortening. In the absence of laboratory tests or code-recommended values, the base shrinkage strain (SH_0) can be assumed to be 500 to 600 micro-strain for water-to-cement ratios between 0.4 to 0.45.

The base shrinkage strain must be adjusted for the ambient relative humidity (k_{RH}) and the volume-to-surface ratio of the member ($k_{v/s}$).

$$SH = SH_0 \times k_{RH} \times k_{v/s} \quad (\text{Exp Q.2.1-1})$$

Adjust the base shrinkage strain by the coefficient k_{RH} given in the following Table.

TABLE Q.2.1-1 Factors for Correction of Base Shrinkage for Relative Humidity (T188)

Relative Humidity	40	50	60	70	80	90	100
k_{RH}	1.43	1.29	1.14	1.00	0.86	0.43	0.00

Members with higher volume-to-surface (V/S) ratios will lose less moisture and therefore tend to shrink less. Solid flat slabs, for example, will shrink less than waffle slabs. The recommended base shrinkage strain is based on a volume-to-surface ratio of 1.5 inch (38 mm). Use the following relationships to adjust the base shrinkage for other cross-sections:

The base shrinkage strain recommended was based on a volume to surface ratio equal to 1.5 inch (38 mm). Use the following relationships to adjust the base shrinkage for other cross-sections:

$$k_{v/s} = [1064 - 94(V/S)]/923 \quad \text{US units (V/S is calculated in inches)} \quad (\text{Exp Q.2.1-2})$$

$$k_{v/s} = [1064 - 3.7(V/S)]/923$$

SI units (V/S is calculated in mm) (Exp Q.2.1-3)

The surface area used in determining the volume to surface area should include only the area that is exposed to atmospheric drying. For poorly ventilated enclosed cells, only 50% of the interior perimeter should be used in calculating the surface area.

Example: Q.2.1-1

Calculate the volume to surface ratio of the following sections:

(i) Slab of uniform thickness h

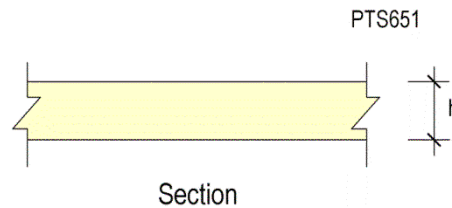

FIGURE Q.2.1.1-1 Member with Uniform Thickness

For a strip of unit width:

$$V/S = (1 \times h) / (2 \times 1) = h/2$$

Hence, for a 10 in. (250 mm) slab, $V/S = 5$ in. (125 mm)

(ii) Waffle slab with the following dimensions for each waffle:

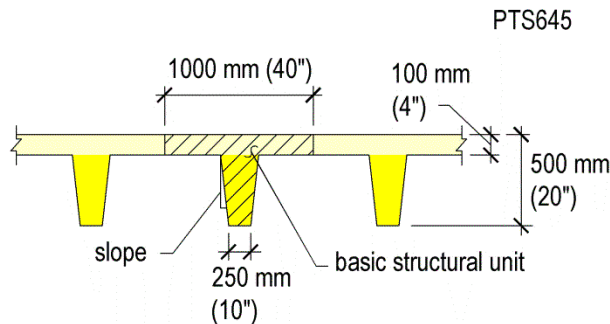

FIGURE Q.2.1.1-2 Section; Waffle Slab

Given

- Width = 1000 mm (40 in.)
- Depth = 500 mm (20 in.)
- Stem width = 250 mm (10 in.)
- Flange depth = 100 mm (4 in.)

Solution

$$\begin{aligned}
 V &= 1000 \times 100 + 250 \times 400 = 200000 \text{ mm}^2 \\
 S &= 1000 \times 2 + 400 \times 2 = 2800 \text{ mm} \\
 V/S &= 200000/2800 = 71.43 \text{ mm (2.81 in.)}
 \end{aligned}$$

Example Q.2.1-2

For a base shrinkage strain of 550 micro strain, what is the long-term shrinkage strain (SH) of a 250 mm (10 in) slab of uniform thickness at a location with an ambient relative humidity $H=80\%$.

Shrinkage strain, $SH = SH_0 \times k_{RH} \times k_{v/s}$

$$SH_0 = 550 \times 10^{-6}$$

$$k_{RH} = 0.86 \quad [\text{From Table Q.2.1-1}]$$

$$V/S = h/2 = 250/2 = 125 \text{ mm (5 in.)}$$

$$\begin{aligned}
 k_{v/s} &= [1064 - 3.7 (V/S)]/923 = \\
 &= [1064 - 3.7 \times 125]/923 = 0.65 \quad \text{SI units (mm)}
 \end{aligned}$$

$$\begin{aligned}
 k_{v/s} &= [1064 - 94 (V/S)]/923 = \\
 &= [1064 - 94 \times 5]/923 = 0.64 \quad \text{US units (inch)}
 \end{aligned}$$

$$\text{Shrinkage strain, } SH = 550 \times 10^{-6} \times 0.86 \times 0.65 = 307 \times 10^{-6}$$

Q.2.2 Shortening from Creep

Creep is primarily a function of applied stress. Creep shortening of concrete under a sustained load is generally between 1.5 to 4.0 times the initial elastic shortening; the actual value is predominantly dependent on the age of the concrete when the load is applied. The base creep coefficient, CR_0 generally used for the post-tensioned floor systems in the US, where tendons are typically stressed to their full value three to four days after the concrete is cast, is 2.0. An upper bound value of 2.5 is recommended.

The base creep coefficient CR_0 selected for a floor system must be modified to account for the particulars of the building under consideration.

$$CR_c = CR_0 \times K(PT) \times k_f \times k_{cRH} \times k_c$$

Where,

CR_c = creep coefficient;

CR_0 = base creep coefficient;

$K(PT)$ = correction factor for the average precompression from post-tensioning;

k_f = correction factor for concrete strength;

k_{cRH} = correction factor for the ambient humidity; and

k_c = correction factor for volume to surface ratio.

The correction factor $K(PT)$ is 1.0 for the average precompression values commonly used in buildings (125 to 300 psi; 0.84 to 2 MPa) and the commonly used concrete strengths. This simplifies the calculation of shortening due to creep effects to the following:

$$CR_c = CR_0 \times k_f \times k_{cRH} k_c \quad (\text{Exp Q.2.2-2})$$

The other correction factors are:

$$k_f = \frac{1}{0.67 + \frac{f_c^i}{9}} \quad (\text{US units; } f_c^i \text{ in ksi}) \quad (\text{Exp Q.2.2-3})$$

$$k_f = \frac{62}{42 + f_c^i} \quad (\text{SI units, } f_c^i \text{ in MPa}) \quad (\text{Exp Q.2.2-4})$$

$$k_{cRH} = (1.58 - H/120) \quad (\text{Exp Q.2.2-5})$$

Where, H is the ambient relative humidity at project location.

The primary impact of the volume-to-surface ratio on creep shortening is during the first few months, when the creep of concrete is more significant. The impact of volume to surface ratio on the long-term creep of a member is not as significant. The following relationships give the adjustment to the base creep coefficient:

$$k_c = \left[\frac{1.80 + 1.77 e^{-0.54(V/S)}}{2.587} \right] \quad (\text{US units; in.}) \quad (\text{Exp Q.2.2-6})$$

$$k_c = \left[\frac{1.80 + 1.77 e^{-0.0213(V/S)}}{2.587} \right] \quad (\text{SI units; mm}) \quad (\text{Exp Q.2.2-7})$$

Q.2.3 Elastic Shortening

Elastic shortening is an immediate response of a member to compression. To estimate elastic shortening, the precompression is calculated using the average force of the tendons over the length of a member divided by the member's cross-sectional area tributary to the tendons. In practice, the average force over the design strip³ is used in the calculation.

Average strain due to elastic shortening is:

$$ES = (P/A)/E_{ci} \quad (\text{Exp Q.2.3-1})$$

³ A design strip would be a beam with its entire tributary or a line of column supports with their tributary area on either side.

Where,

- ES = total strain due to average elastic shortening;
 P = average value of prestressing force allowing for friction losses, but not long-term stress losses⁴;
 A = cross-sectional area of the member's tributary; and
 E_{ci} = modulus of elasticity of the concrete at the time of stressing.

A. Designs Based on US Codes. There are two methods commonly used.

For design in the US, E_{ci} is typically calculated as⁵:

$$E_{ci} = 33W_c^{1.5} \sqrt{f'_{ci}} \quad \text{in US units}$$

- f'_{ci} = compressive strength of concrete cylinder at time of stressing, psi;
 W_c = weight of one cubic ft of concrete, between 90 and 155 lb/ft³; and
 E_{ci} = modulus of elasticity of concrete at day of stressing, psi.

In SI units the relationship is:

$$E_{ci} = 0.043W_c^{1.5} \sqrt{f'_{ci}} \quad (\text{Exp Q.2.3A-2})$$

Where,

E_{ci} is in MPa; W_c in kg/m³ and f'_{ci} in MPa

Usually the cylinder strength at stressing will be known; most project specifications prohibit stressing the tendons until the concrete reaches a minimum cylinder strength specified in the project's specifications. If the cylinder strength at stressing is not available, the following relationship can be used to estimate f'_{ci} :

$$f'_{ci} = \frac{1.45t^{0.75}}{t^{0.75} + 5.5} f'_c \quad (\text{Exp Q.2.3A-3})$$

B. Design Based on European Code EC2: Using EC2 the modulus of elasticity of concrete cylinder at 28 days E_c is given by:

⁴ When tendons are stressed one after the other, the force in previously stressed tendons will decrease as subsequent tendons are stressed and cause elastic shortening of the member. Since the relationship is based on average precompression, it is not necessary to adjust for the stressing sequence.

⁵ ACI 318-11, Section 8.5.1

$$E_c = 22 \times 10^3 \left[\frac{(f_{ck} + 8)}{10} \right]^{0.3} \quad \text{in SI units (Exp Q.2.3B-1)}$$

The modulus of elasticity on day (t) is given by:

$$E_c(t) = \left[\frac{f_{cm}(t)}{f_{ck} + 8} \right]^{0.3} E_c \quad \text{in SI units (Exp Q.2.3B-2)}$$

Where,

$$f_{cm}(t) = \exp \left\{ s \left[1 - \left(\frac{28}{t} \right)^{0.5} \right] \right\} (f_{ck} + 8) \quad \text{(Exp Q.2.3B-3)}$$

$f_{cm}(t)$ = mean compressive strength of concrete cylinder on day “ t ,”

t = age of concrete in days; and

s = a coefficient which depends on the type of cement, (this is 0.2 for most common cements).

Q.2.4 Temperature Effects

Temperature effects are reversible, depending on whether there is a rise or fall in temperature. As a result, they are generally not considered when calculating the long-term shortening of a floor slab. However, in cases of exposed structures such as parking garages where there are seasonal extremes in the temperature, the effects can be quite significant and should be accounted for. The change in the length of a member is given by:

$$d = L \times T \times \alpha \quad \text{(Exp Q.2.4-1)}$$

Where,

d = change in length;

T = change in temperature (degrees F or C); and

α = coefficient of thermal expansion.

In the absence of more precise data, the coefficient of thermal expansion of concrete can be taken as:

$$\alpha = 6.0 \times 10^{-6} / F^\circ$$

$$\alpha = 10.1 \times 10^{-6} / C^\circ$$

Q.2.5 Shortening Example

Estimate the long-term shortening of the following post-tensioned slab.

GIVEN

Concrete	5000 psi	(34 MPa)
Slab thickness	8 inch	(200 mm)

Length of the slab	100 ft	(30 m)
Relative humidity H	75%	
Average precompression	150 psi	(1.0 MPa)
Stressing day	3 day	(3 day)
Seasonal change in temperature	25 F°	(14C°)

REQUIRED

Total long-term unrestrained change in length

In the absence of more accurate data, the following somewhat conservative assumptions can be used for the base values ⁶. These values are applicable for most areas, unless the concrete is of poor quality, in which case higher values are recommended.

Base shrinkage strain $SH_0 = 600 \times 10^{-6}$

Base creep coefficient $CR_0 = 2.5$

Elastic shortening strain, ES :

$$ES = (P/A) / E_{ci}$$

The concrete strength at stressing (f'_{ci}) is not known so must be estimated from its specified (28-day) strength.

$$f'_{ci} = \frac{1.45t^{0.75}}{t^{0.75} + 5.5} f'_c$$

$$f'_{ci} = \frac{1.45 \times 3^{0.75}}{3^{0.75} + 5.5} 5000 = 2124 \text{ psi (14.64 MPa)}$$

$$E_{ci} = 33 \times 150^{1.5} \sqrt{2124} = 2794010 \text{ psi (19264 MPa)}$$

Hence, the elastic shortening strain of the slab is:

$$ES = (P/A) / E_{ci}$$

$$ES = 150 / 2794010 = 54 \times 10^{-6}$$

Shrinkage shortening strain, SH :

$$SH = SH_0 \times k_{RH} \times k_{w/s}$$

⁶ For structures in USA, and where strict quality control is exercised, assume base creep coefficient = 2 and base shrinkage strain = 400 micro strain

From table Q.2.2-1, the correction for relative humidity $H=75\%$ is interpolated from the given values.

$$k_{RH} \text{ for } 70\% = 1.00$$

$$k_{RH} \text{ for } 80\% = 0.86$$

$$k_{RH\ 75} = 1.00 - 0.5 (1.00 - 0.86) = 0.93$$

Correction for volume-to-surface ratio:

$$V/S = 0.5 \times 8 = 4 \text{ in. } (0.5 \times 200 = 100 \text{ mm})$$

The correction factor $k_{v/s}$ is:

$$k_{v/s} = [1064 - 94 \times 4] / 923 = 0.75 \quad \text{US units}$$

$$k_{v/s} = [1064 - 3.7 \times 100] / 923 = 0.75 \quad \text{SI units}$$

Hence the long-term shrinkage strain is:

$$SH = 600 \times 10^{-6} \times 0.93 \times 0.75 = 419 \times 10^{-6}$$

Creep shortening strain, CR :

$$CR = CR_c \times ES$$

$$CR_c = CR_0 \times k_f \times k_{cRH} \times k_c$$

Correction for concrete strength k_f ;

$$f'_c = 5000 \text{ psi (34 MPa)}$$

$$k_f = 1 / (0.67 + 5/9) = 0.82 \text{ (US units)}$$

$$k_f = 62 / (42 + 34) = 0.82 \text{ (SI units)}$$

Correction for relative humidity

$$k_{cRH} = (1.58 - H/120)$$

$$k_{cRH} = (1.58 - 75/120) = 0.96$$

Correction for the volume-to-surface ratio:

$$V/S = 0.5 \times 8 = 4 \text{ in.} \quad (0.5 \times 200 = 100 \text{ mm})$$

The correction factor k_c is:

$$k_c = (1.80 + 1.77 \times e^{-0.54 \times 4}) / 2.587 = 0.77 \quad (\text{US units})$$

$$k_c = (1.80 + 1.77 \times e^{-0.0213 \times 100}) / 2.587 = 0.78 \quad (\text{SI units})$$

Having obtained the correction factors, the creep coefficient is given by:

$$CR_C = 2.5 \times 0.82 \times 0.96 \times 0.78 = 1.54$$

$$CR = CR_C \times ES = 1.54 \times 54 \times 10^{-6} = 83 \times 10^{-6}$$

Total shortening, without taking temperature effect into account:

$$a = L (ES + SH + CR)$$

$$a = 100 \times 12 \times (54 + 419 + 83) \times 10^{-6} = 0.67 \text{ in. (17 mm)}$$

Temperature effect:

$$d = L \times T \times \alpha = 100 \times 12 \times 25 \times 6.0 \times 10^{-6} = 0.18 \text{ in. (4.6 mm)}$$

Total shortening including temperature effect:

$$= 0.67 + 0.18 = 0.85 \text{ in. (22 mm)}$$

Q.2.6 Estimate of Short-Term Shortening

The short-term shortening of a post-tensioned member can be important when designing for crack mitigation. The amount of shortening at a given time can be estimated from the expected long-term shortening. For the shortening due to creep and shrinkage the following graph can be used [PTI, 1988].

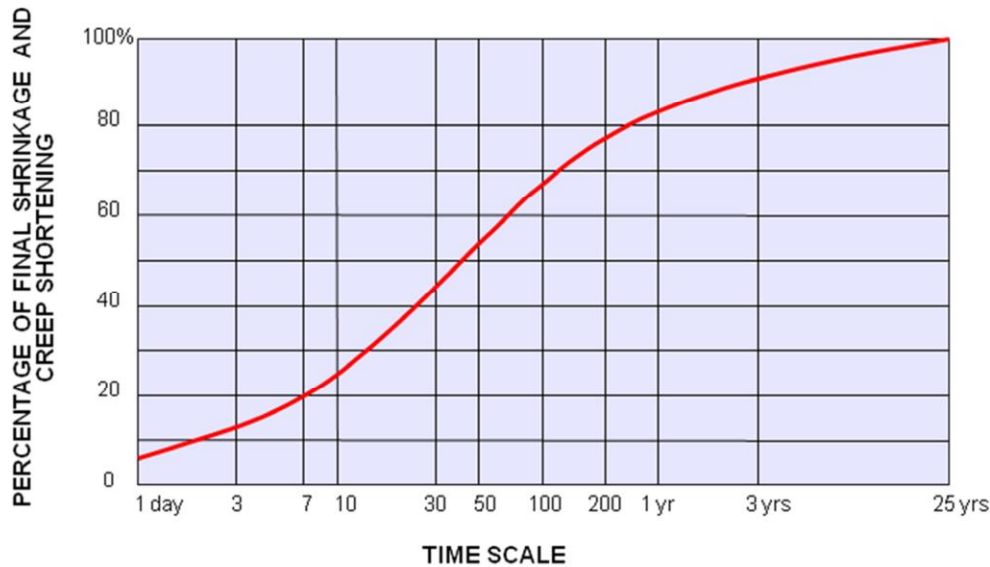

FIGURE Q.2.7-1 Variation of the Combined Creep and Shrinkage Shortening with Time for Typical Post-Tensioned Members (P569)

Q.2.7 Short-Term Shortening Example

If the long-term shortening of a 150-ft (45.72-m) slab is estimated to be 1.25 in. (32 mm), what is the anticipated shortening on day 10 and day 28?

Referring to Fig. Q.2.7-1, the percentage of the shortening due to creep and shrinkage that have taken place by day 10 and day 28 are 24% and 43% respectively. Hence, the estimated shortening will be:

At 10 days: Shortening = $0.24 \times 1.25 = 0.30$ in. (8 mm)

At 28 days: Shortening = $0.43 \times 1.25 = 0.54$ in. (14 mm)

The amount of shortening that takes place between the day 10 and day 28 is:

Incremental shortening = $0.54 - 0.30 = 0.24$ in. (6 mm)

Q.3 MITIGATION OF RESTRAINT CRACKS

This Section describes the steps that post-tensioning design engineers use both to allow for the shortening of post-tensioned members in their designs and to minimize the effects of restraint cracks.

There are various detailing options for construction that can reduce the potential of crack formation. The selection of the proper detail depends, among other factors, on the amount of the anticipated shortening. Crack mitigation design has developed from the practice of design engineers over the years, and the observation of satisfactory performance of the post-tensioned floors where the details were used. The procedure is strictly empirical – that is to say, it is not derived from the principles of mechanics of solids.

Q.3.1 Assumptions and Overview

The principal assumptions for crack mitigation design of post-tensioned floors are:

- ❖ The shortening of a post-tensioned member is a time-dependent phenomenon. Under typical conditions, it will be at least two years before a post-tensioned member can be considered to have undergone its design-significant shortening. In typical construction, it is not practical for a post-tensioned member to be released from its supports long enough for the member to fully undergo its anticipated shortening. Where support restraints are significant, it is acceptable to allow occasional cracks.
- ❖ An acceptable limit (0.25 in.; 6 mm) to restraint shortening is established. The limit is the amount of computed movement of any point on a slab or beam that can be prevented from taking place because of restraint from the supports. In other words, if the computed long-term movement of any point on a post-tensioned member relative to its support does not exceed 0.25 in. (6 mm), the performance of the member with respect to shortening is deemed acceptable.
- ❖ For design purposes, the supporting walls are assumed not to shorten horizontally in the plane of the wall, but are free to bend normal to their plane
- ❖ Once a slab is tied to a wall, it is assumed that the slab's shortening parallel to the wall is fully restrained.

It is re-iterated that the above assumptions, as well as the methods of calculation and detailing that will be discussed, are empirical.

Consider the following example to illustrate the point. Figure Q.3.1-1a shows a post-tensioned floor slab of a podium construction that stretches over two levels of parking to serve two high rise towers one at each end. Recognizing the restraint of the towers and the perimeter walls to the free shortening of the post-tensioned slab between them, delay strips as marked on part (b) of the figure were provided. Delay strips – discussed in detail in Section Q.3.3.3.A – are gaps about 3 ft (1 m) wide that are left open between two segments of a post-tensioned slab, while the rest of the slab is cast. The objective of a delay strip is to allow the member on each side of it to undergo a certain amount of shortening, before the gap is filled to establish the continuity of the two segments on each side. Figure Q.3.1-2 shows an example of a delay strip in construction and after closure.

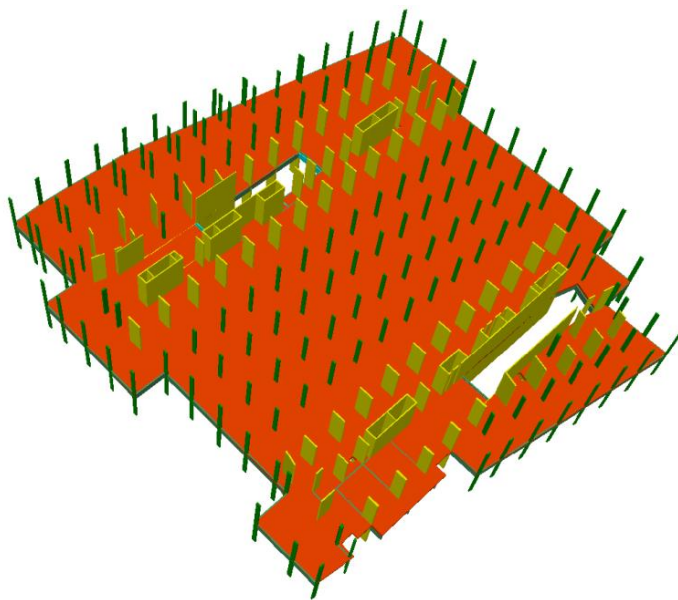

(a) Podium slab with towers on each side (P740)

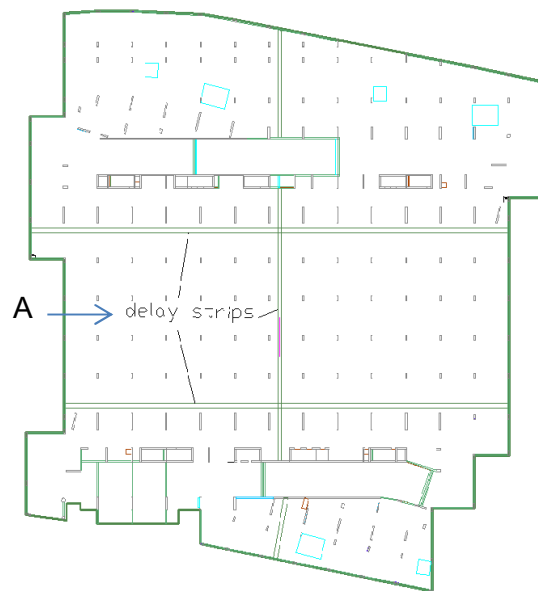

(b) Identification of delay strips on slab (P741)

FIGURE Q.3.1-1 Post-Tensioned Slab with Delay Strips to Mitigate Cracking



(a) Delay strip in preparation using grouted tendons (P746)

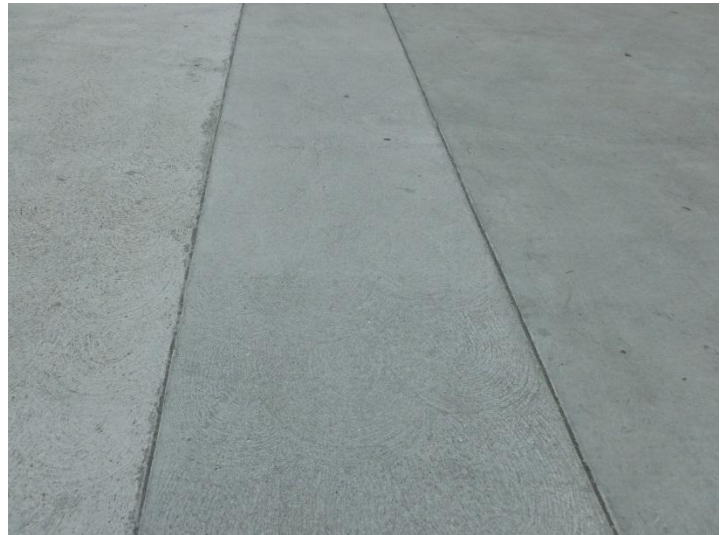

(b) Delay strip closed and completed (P757)

FIGURE Q.3.1-2 Example of a Delay Strips before and after Closure

The question commonly facing a design engineer is “How long does the delay strip have to be left open ?” An open delay strip often hinders the progress of construction; contractors typically want to close the delay strip gaps as soon as possible.

As an example of how to determine this timing, consider delay strips ‘A’ in part (b) of the figure. Using the shortening calculations outlined in Q.2, it is determined that the total long-term shortening of the concrete pour identified by the delay strips is 0.84 in. (21 mm); the shortening of each segment will thus be 0.42 in. (11 mm). This is more than the 0.25 in. (6 mm) that is deemed acceptable. The delay strip must remain open until all but 0.25 in. of the shortening on either side of the strip has occurred. The following explains the calculation:

Total shortening on either side of the delay strip = 0.42 in. (11 mm)

Restrained shortening to be allowed = 0.25 in. (6 mm)

Shortening to take place, before closing the delay strip = $0.42 - 0.25 = 0.17$ in. (4 mm)

Ratio of unrestrained shortening to total shortening = $0.17/0.42 = 0.41 = 41\%$

The delay strip has to remain open until 41% of the anticipated long-term shortening of the slab segments has taken place. Referring to Fig. Q.2.7-1, this corresponds to about 25 days, at which time approximately 41% of the computed shortening will take place. Thus, the delay strip should remain open for 25 days.

Q.3.2 Characteristics of Restraint Cracks

Cracking is initiated when the stress in the concrete exceeds the concrete’s tensile strength. Once initiated, the propagation and extent of cracking depends on the cause, as well as the detailing of the reinforcement at the crack location. For post-tensioned floor systems, three distinct crack types can be identified. These are: (i) plastic shrinkage cracks - shallow, closely-spaced irregular surface cracks caused by the shrinkage of improperly cured concrete (Fig. Q.3.2-1a); (ii) restraint cracks from the resistance of the supports to free shortening of the member; and finally (iii) strength cracks that occur when the applied moment exceeds the cracking moment of a section.

There are typically fewer restraint cracks than the other two types, particularly when unbonded tendons are used. The restraint cracks are generally wider, spaced farther apart and extend deeper into the slab than the other two types of cracks. In many cases, restraint cracks extend through the entire depth of a slab (Fig. Q.3.2-1 and 2).

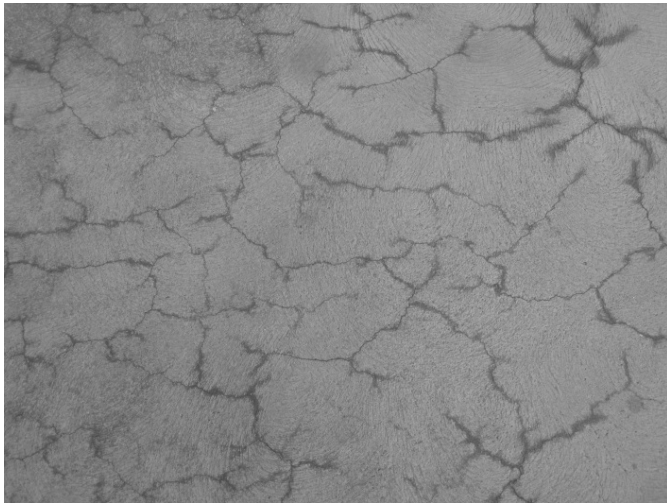

(a) Shallow plastic shrinkage cracks (P753)



(b) Restraint crack, long and few in number (P751)

FIGURE Q.3.2-1 Plastic Shrinkage and Restraint Cracks

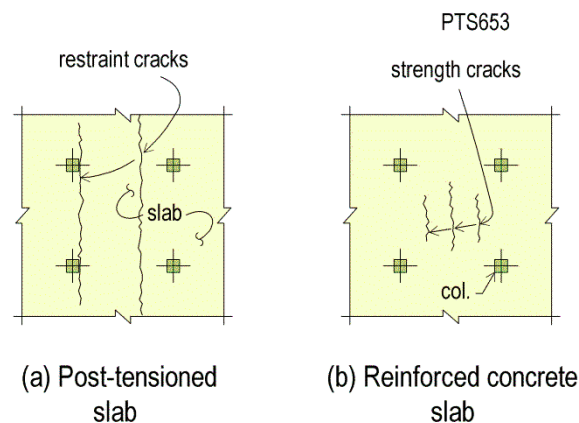

FIGURE Q.3.2-2 Plan of Reflected Ceiling; Cracking in Post-Tensioned and Conventionally Reinforced Slabs

In conventionally-reinforced concrete slabs, the spacing between the cracks is on the order of slab thickness, whereas in post-tensioned slabs the spacing is usually on the order of the length or width of the panel. In most cases, there is only one crack per panel in a post-tensioned slab. If there is more than one crack, the cracks are typically spaced at least one-quarter span apart. Restraint cracks in post-tensioned slabs typically do not occur at the locations of maximum moments, such as midspan or face of supports. They usually occur at axially weak locations like construction joints, delay strips, and where there are fewer reinforcing bars, such as at the end of the top bars over the supports.

Figure Q.3.2-3 shows two examples of typical restraint cracks in podium slabs constructed with unbonded tendons. In each case, the slab is the first elevated floor above the foundation. The long cracks shown extend through the entire depth of the slab. A significant portion of the post-tensioning in the longer direction has been diverted to the walls on the longer sides leading to a total loss of precompression in the left-right direction between the two long cracks (part b of the figure).

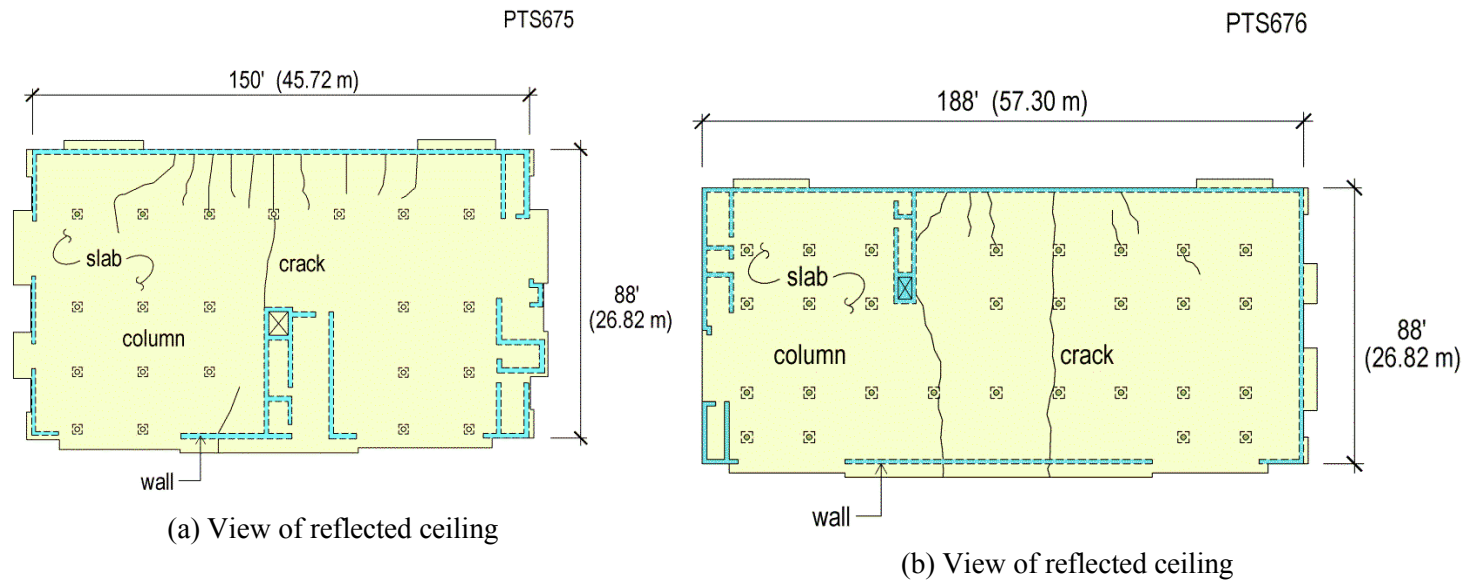

FIGURE Q.3.2-3 Plan of Reflected Ceiling; Restraint Cracks in Post-Tensioned Slab (Village Serramonte, CA)

Cracks due to local concentration of stresses at discontinuities (Fig. Q.3.2-4) in slab geometry can be reduced in width and number by addition of trim bars, but are difficult to fully eliminate, if the discontinuity is a cold joint between two segments of a post-tensioned slab. Figure Q.3.2-5 is view of a discontinuity in a post-tensioned ground-supported slab. The addition of a large number of trim bars at the corners reduced the extent of the cracking, but did not fully eliminate it. Obviously, the slab has to crack before the trim bars can be effectively mobilized to control the width and extent of cracking. The same condition would apply to suspended slabs.

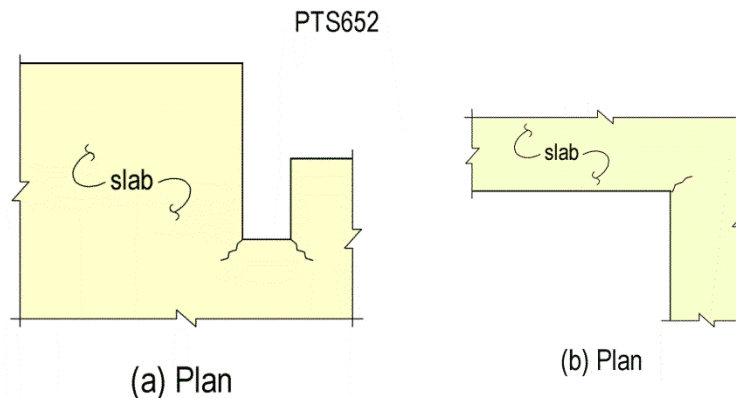

FIGURE Q.3.2-4 Cracking from Stress Concentration at Discontinuities (PTS652)



(a) Trip bars at construction joint (P758)



(b) Crack formation at construction joint (P759)

Q.3.2-5 Crack Formation at Discontinuities (Belly Rast Logistics Center; Moscow)

Cracks formed in a post-tensioned slab because of insufficient strength will be different from those caused by support restraint. They will also be different from those formed in a conventionally reinforced slab because of insufficient strength. As illustrated in Fig. Q.3.2-6, cracks due to shortfall of strength in post-tensioned slabs will be fewer in number than the corresponding conventionally reinforced slabs; will form at the locations of maximum demand in bending; and will not extend through the depth of the slab. In addition, strength cracks in post-tensioned members are often accompanied by noticeable deflections – a condition that is generally absent where cracking is due to restraint of supports.

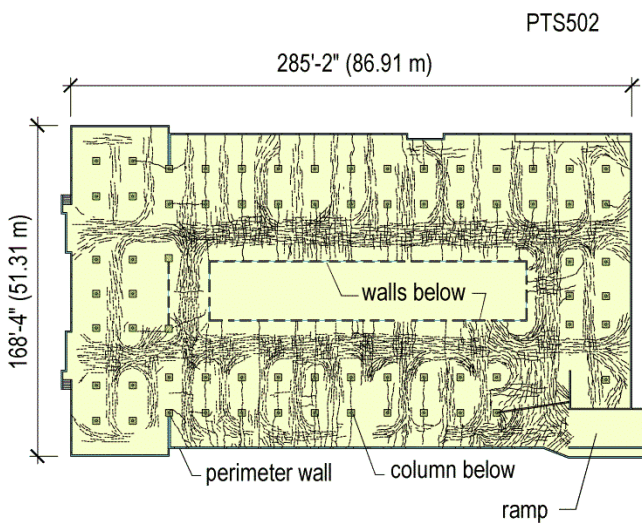

(a) Conventionally reinforced slab

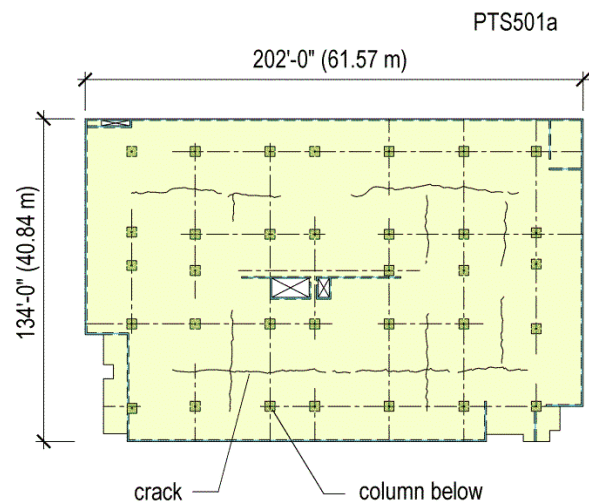

(b) Post-tensioned slab (Glendale CA)

Q.3.2-6 Plan of Reflected Ceiling; Crack Formation at Slab Soffit due to Shortfall in Strength

Q.3.3 Crack Mitigation Options

The options available for crack mitigation can be categorized as follows:

- 1 – Favorable layout
- 2 – Structural separation
- 3 – Delay (closure) strips; joints; favorable pour sequence
- 5 – Permanent released connections
- 6 – Other released connections
- 7 – Detailing

It is emphasized, as will be discussed in Section Q.4.2, that these crack mitigation schemes are only necessary for the lower levels of a multi-story post-tensioned building. Crack mitigation may be necessary for the first, and possibly second and third levels above the foundation.

Q.3.3.1 Favorable Layout

Ideally the building can be designed with recognition of the shortening that will occur in the post-tensioned members and the supports will be located so as to minimize the restraint. But, while a desirable option, this is seldom possible. Fig. Q.3.3.1-1 shows support layouts that are favorable for crack mitigation and those that provide significant restraint to slab shortening,

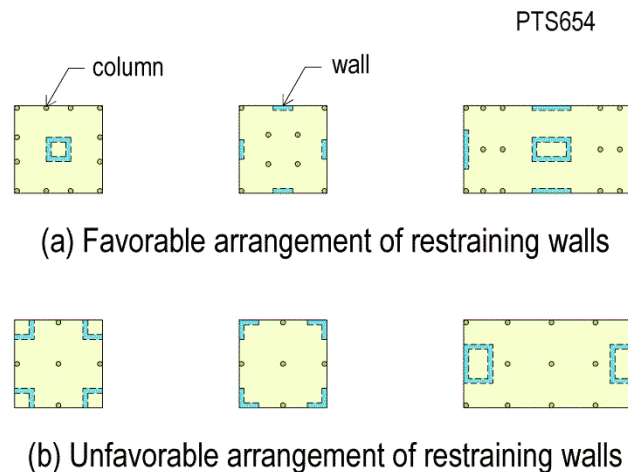

FIGURE Q.3.3.1-1 Examples of Favorable and Unfavorable Arrangements of Shear Walls for Mitigation of Restraint Cracks at Lower Levels of High Rise Buildings (P754) (PTS654)

Q.3.3.2 Structural Separation

In some cases, it may be necessary to divide very large slabs into segments using permanent, structural separations. The following guidelines are suggested [Aalami, et al 1988].

- ❖ Unless special provisions are made, limit the length of contiguous post-tensioned slabs to 375 ft (114 m). For slabs longer than 375 ft (115 m), provide a structural separation to reduce the potential for restraint cracks;
- ❖ For slabs longer than 250 ft (76 m), but not exceeding 375 ft (114 m), provide a central delay strip (closure pour); and
- ❖ For slabs or slab regions shorter than 250 ft (76 m), design the slab for the anticipated long-term shortening.

Figure Q.3.3.2-1 is an example of a structural separation (a physical gap separating two slab regions) for a long slab. Slabs with an irregular geometry are particularly vulnerable to cracking when restrained by supports. Figure Q.3.3.2-2a shows a

small slab area appended to a larger rectangular shaped region. The structural separation shown in the figure between the two post-tensioned slab regions is designed to reduce cracking.

Structural separations are similar to expansion joints designed for temperature changes or separations designed to minimize damage from seismic events. The primary difference is that restraint separations are not required once the bulk of the slab shortening takes place (typically a period of several months). Thus restraint separations do not have to be designed to remain open and functional throughout the life of the structure. Also, restraint separations do not have to be continued through the entire height of the building; typically, two to three levels above the foundation will suffice. Seismic and temperature separations, on the other hand, should extend through the entire height of the building.



FIGURE Q.3.3.2-1 Plan; Structural Separation in a Long Post-Tensioned Floor Slab (P760)

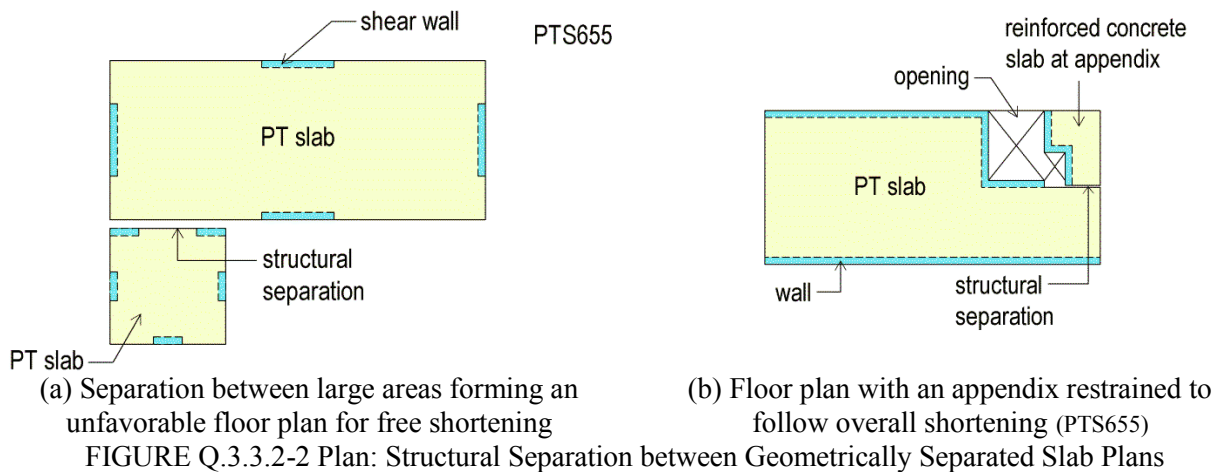

Q.3.3.3 Delay (closure) strips; joints; Favorable pour sequence

The following describes the features of each of the crack mitigation schemes listed. An example demonstrates the application of each scheme.

A. Delay Strips: also referred to as closure or pour strips are temporary separations of approximately 36 in. (1 m) between two regions of slab which are constructed and post-tensioned separately. The width of the gap is to accommodate the length of the jacks that are generally used to stress the live end of the tendons that terminate on each face of the strip. Where tendons need not be stressed from the opening of the gap, the width of the delay strip can be much shorter. In this

case, the gap will be wide enough to provide structural continuity between the overlapping reinforcement that extends from each side into the gap.

Cast regions on either side of the delay strip are allowed to shorten independently. Once the anticipated shortening has taken place, the gap between the two regions will be cast. Non-shrink concrete is preferred in filling the gap. The overlapping reinforcement that extends from the concrete slab into each side into the delay strip provides the structural continuity of the slab over the strip once the floor is placed in service. Figures Q.3.3.2A-1 and 2 show construction views of the several delay strips.



(a) Delay strip after concrete on one side is cast (P762)



(b) Delay strip after concrete on both sides has been cast (P764)

FIGURE Q.3.3.2A-1 Delay Strips in Construction



FIGURE Q.3.3.2A-2 Delay Strips in Podium Slab Joining a High Rise to Mitigate Crack Formation (P813)

If the support layout is such that the panels are all of approximately equal size, pour strips are typically located at the quarter span of a panel, because this is where the moment is the smallest (Fig. Q3.3.3A-2). The tendons are anchored at the centroid of the slab on each face of the strip. The tendon profile within the segments on either side of the gap should be as close as possible to the profile of the typical spans. Fig. Q3.3.3A-3 shows a computer model of the tendon arrangement at a delay strip. The short quarter-span overhang does not have to be supported, but the tip of the three-quarter span segment should be propped until the strip is cast and cured. Depending on the amount of post-tensioning, the

short overhang will tend to rise, while the propped segment will tend to deflect downwards. In theory, there will be a lack of alignment between the two sides of the gap but in most slabs, the lack of alignment will be within construction tolerances.

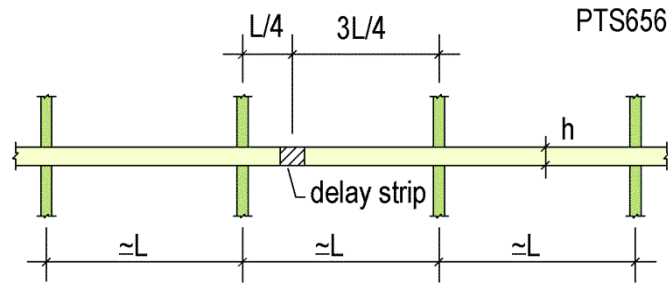

(a) Elevation ; approx. equal spans

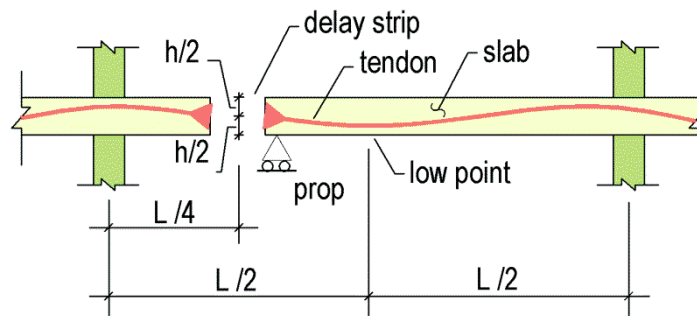

(b) Delay strip at quarter span

FIGURE Q3.3.3A-2 Suggested Delay Strip Location of Layout with Equal Spans (PTS656)

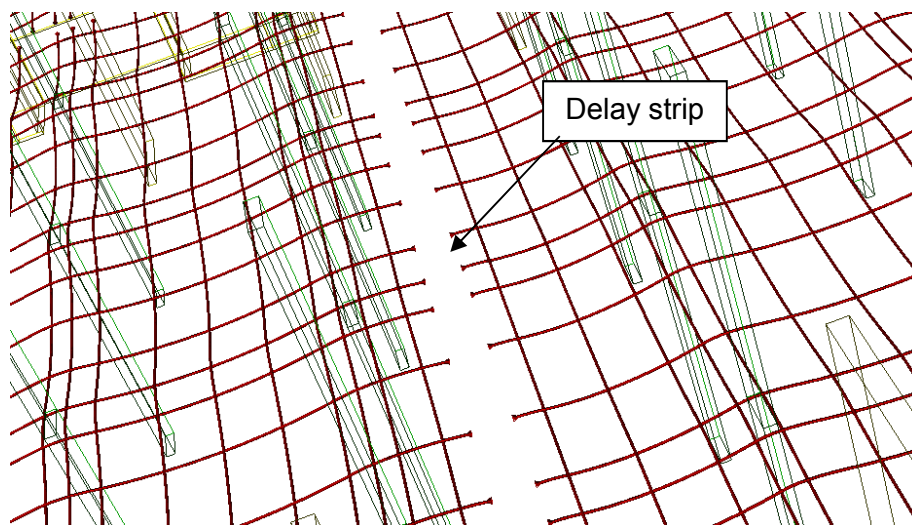
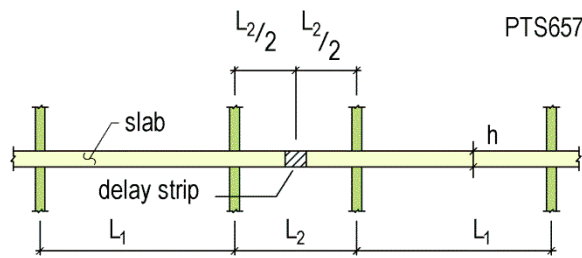

FIGURE Q3.3.3A-3 Example of a Tendon Layout with Delay Strip at Quarter Span, Showing the Overhang and Long-Span Tendon Profile (P764)

When the support layout results in different span lengths, the closure strip should be positioned in the middle of a short span, if possible (Q3.3.3A-4). The tendons from each side will again be anchored at the mid-depth of the slab; both slab edges should be propped until the gap is cast and cured.

Figure (Q3.3.2A-5) is an example of a delay strip located at mid-span. If the objective of the delay strip is to allow shortening of the slab and reduce cracking, it is generally not necessary to continue the delay strip through all levels of a multi-story building. Two to three levels will typically be adequate. If the objective is to provide access for stressing tendons, the delay strip will be required on all levels where such access is required.



(a) Elevation $L_2 \ll L_1$

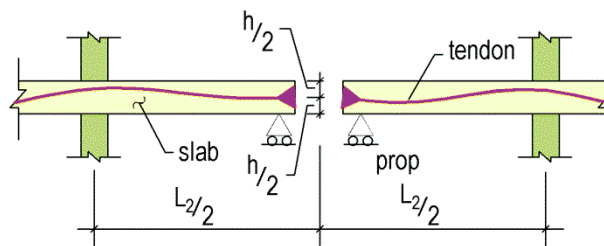

(b) Delay strip at mid span

FIGURE Q3.3.3A-4 Suggested Delay Strip Location of and Tendon Layout for Panels with Unequal Spans

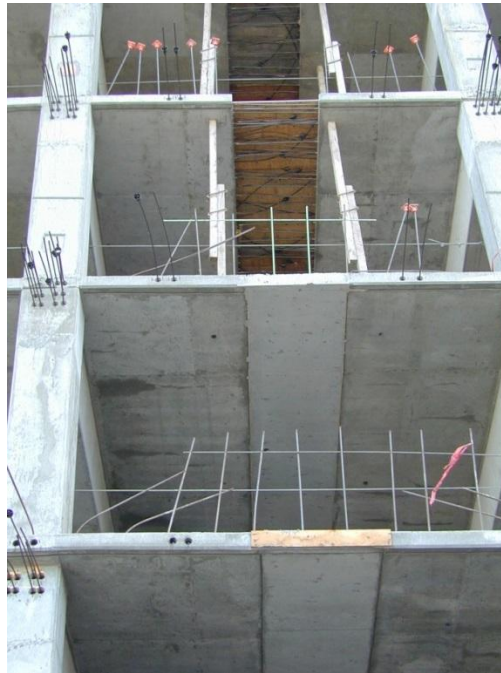

FIGURE Q3.3.3A-5 Example of Delay Strip Positioned in Middle of a Span (P???)

Strictly speaking, the reinforcement of a delay strip falls in the realm of “phased construction”, where the design recognizes that the structure is constructed and subjected to load in more than one configuration – in this case selfweight and live load. There is commercially-available software⁷ that handles the phased construction aspect of the delay strip, including allowance for the shortening that takes place while the gap is open. However, for common building construction, design engineers typically model the tendons as terminating at the delay strip (Fig. Q3.3.3A-3); design the member with the delay strip closed; determine the demand actions (moments, shears) across the gap; and design for them using conventional reinforcement. Fig. Q3.3.2A-6 shows the generic detail used for a delay strip in a post-tensioned slab with unbonded tendons.

Figure Q3.3.2A-7 shows a delay strip between a perimeter wall and a slab post-tensioned with bonded tendons. The delay strip runs parallel to the wall temporarily separating the floor slab from its support.

⁷ ADAPT-ABI www.ADAPTsoft.com

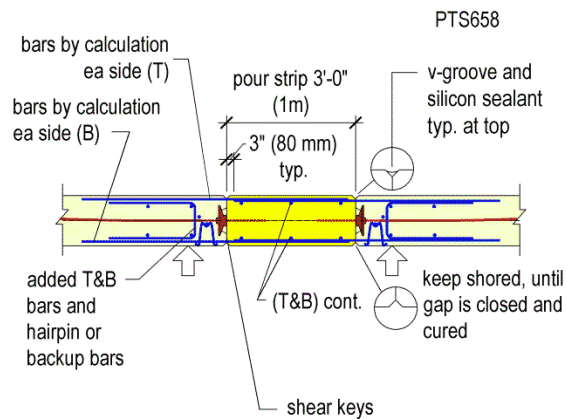

FIGURE Q3.3.3A-6 Typical Detail of a Delay Strip for Unbonded Tendon Construction (PTS658)



FIGURE Q3.3.3A-7 Delay Strip next to a Perimeter Wall Designed to Allow Stressing (P770)

B. Joints: Construction joints are separations that break an otherwise contiguous concrete slab into two concrete placements. One side of the joint is cast and allowed to cure before the adjoining part is placed. Once both sides are cast, the slab is intended to respond as a continuous member in resisting the applied loads. A construction joint (shown in Fig. Q3.3.3B-1a) differs from a cold joint in that (i) it is an intentional joint as that divides a large slab area into manageable pour sizes as opposed to the location at which a concrete batch is finished and (ii) there may be a delay of three to seven days between the first and second pour. The unrestrained joint allows the segment that is cast first to undergo a portion of its shortening before it is locked to the remainder of the structure.

Unlike delay strips, where the tendons terminate at the face of the strip gap, the post-tensioning tendons are continuous across a construction joint. To reduce the loss in prestress due to friction, long tendons are often stressed at the construction joint (part b of the figure).

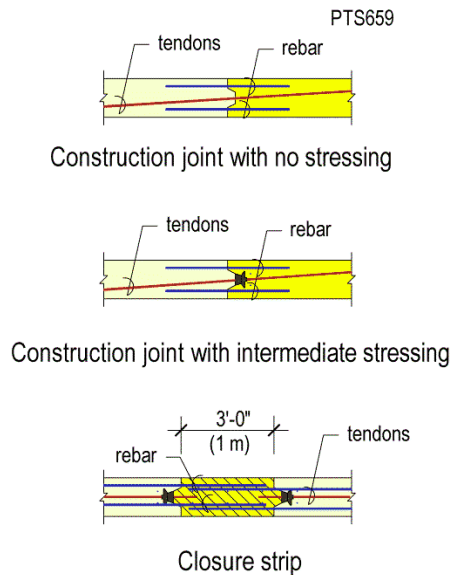

FIGURE Q3.3.3B-1 Several Options of Allowance for Temporary Shortening (PTS659)

Figure Q3.3.3B-2 is a schematic of construction joints with and one without intermediate stressing. Figure Q3.3.3B-3 shows a construction joint with intermediate stressing, where tendons from the cast side have already been stressed.



(a) Construction joint without intermediate stressing. (P659) (b) Construction joint with intermediate stressing (P810)

FIGURE Q3.3.3B-2 Construction Joints with and without Intermediate Stressing. Recessed Shear Keys Enhances the Shear Transfer Across the Joint.

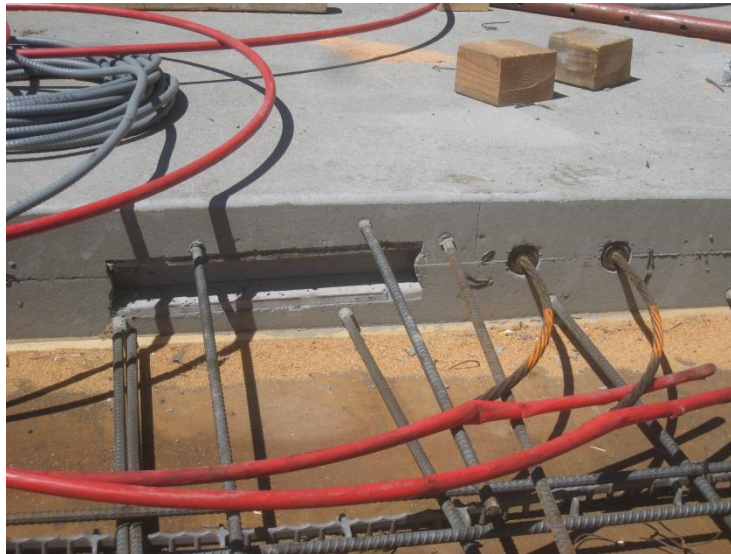
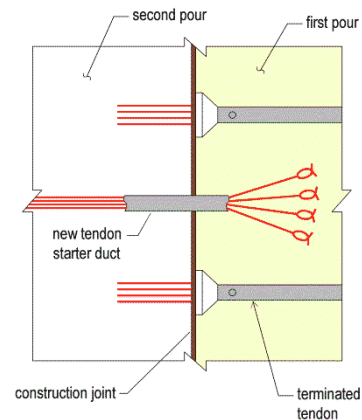

FIGURE Q3.3.3B-3 Construction Joint with Intermediate Stressing Showing the Shear Keys and Stressed Tendons (P812)

Not all bonded post-tensioning systems include the hardware required to allow stressing at a construction joint. The alternative is either to terminate the tendon at the face of the joint or use two partial-length tendons and overlap the dead (fixed) ends at the construction joint.



(a) Overlapping tendons at a construction joint with intermediate stressing (P765)



(b) Construction joint with intermediate stressing using overlapping tendons (PTS739)

Q3.3.3B-3 Construction Joints with Intermediate Stressing

C. Temporary Released Connections: Temporary release connections allow a post-tensioned member to shorten for a limited period of time by allowing it to freely slide over its support before it is locked to the support for full force transfer. The most common temporary release connections are between walls and slabs. Figure Q.3.3.3C-1 shows two examples of temporary releases. In each case, the wall is separated from the slab through a slip material. In part (a), the relatively flexible corrugate tube is initially filled with a compressible material. Once the slab is cast and has undergone its design-intended shortening, the compressible material is removed and the tube is filled with high strength grout to establish the means of horizontal force transfer between the wall and slab. In part (b) the dowels extending from the lower wall into the slab are initially encased in a non-rigid material such as Styrofoam. The non-rigid material is removed and replaced with non-shrink grout to fix the connection.



(a) Dowels extend into slab (P766)

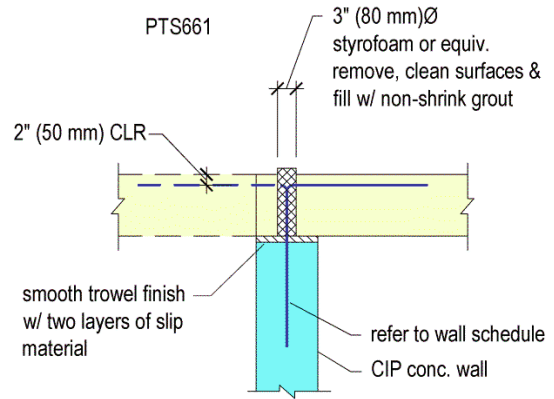

(b) Structural detailing of the release (PTS661a)

FIGURE Q.3.3.3C-1 Temporary Release between Wall and Slab. The Fill in the Corrugated Tube in part (a) is Replaced with Grout

Figure Q.3.3.3C-2 is another example of a temporary release. The wall is topped with slip material and dowels from the lower wall will connect to the wall above. The tubes will be grouted once the required amount of shortening has occurred.

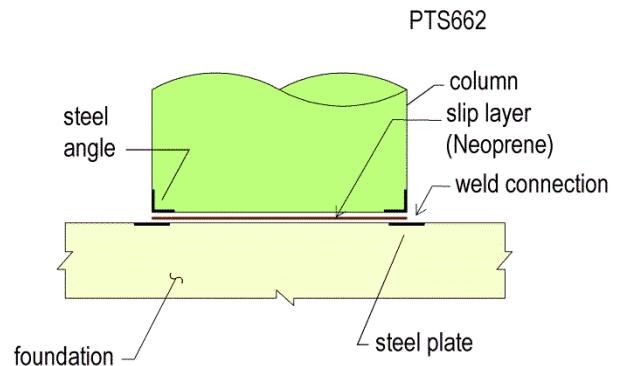

FIGURE Q.3.3.3C-2 Example of a Slab Release; Walls from below Tie to the Walls above (P810).

A column/slab release can also be provided at the base of a column. In the case of the Moscone Exhibition Hall in San Francisco, the heavy construction long-span roof of the hall required strong columns that at the base would have restricted the shortening of the roof under post-tensioning. The bases of the columns were separated from the foundation by elastomeric (Neoprene) pads. After the roof had undergone sufficient shortening, steel angles embedded in the columns were welded to plates embedded in the foundation, thus providing the necessary fixity for the column-foundation connection (Fig. Q.3.3.3C-3).



(a) Column base on slip pad (P767)



(b) Schematic of temporary base connection (PTS662)

FIGURE Q.3.3.3C-3 Example of a Temporary Column Base Foundation Release (San Francisco)

D. Favorable Pour Sequence. Large slabs are typically broken down into pours of around 2000 sf (approx. 200 m²). This size can be handled by a typical construction crew and corresponds to the amount of formwork that small to medium size contractors stock. For improved crack mitigation, the pours should be done in a checkerboard sequence, to allow as much free shortening of each slab segment as possible. This, however, is not possible in all cases and will probably not be how the contractor would prefer to sequence the pours.

Q.3.3.4 Permanent Release Connections: Permanent release connections are used when there is no structural need for force transfer between the slab and its support in the direction of the release. A permanent release allows unimpeded movement between the slab and its support at the release. Permanent release connections come in different styles. A permanent wall/slab release can be used when only vertical forces need to be transferred from the slab to the wall; the forces in other directions, such as forces from wind or earthquake, will be designed to be transferred to the supports at other connections.

Figure Q.3.3.4-1 shows the schematics of several wall/slab connections. Examples are shown in Fig. Q.3.3.4-2. The usefulness of the dowel shown in Fig. Q.3.3.4-1(d) is questionable. Its purpose is to restrain horizontal displacement of the slab relative to its support in a catastrophic event, such as a major earthquake. But it is unlikely that a bar of that size without positive anchorage in the slab would provide much resistance to a catastrophic event that could move the slab support off the wall. The detail shown in Fig. Q.3.3.4-1(b) allows movement within the limits anticipated by the slab shortening, but will provide resistance in a catastrophic event.

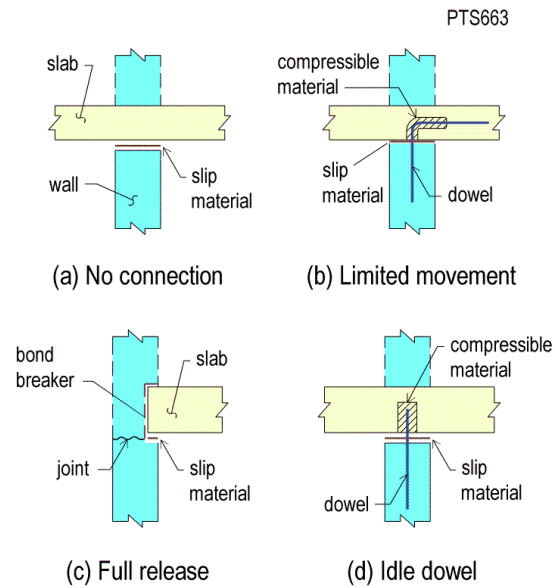

Q.3.3.4-1 Schematics of Several Wall/Slab Release Options



(a) Permanent release for horizontal movement (P768)



(b) Permanent wall slab-band release (P769)

Q.3.3.4A-2 Construction Examples of Wall-Slab Permanent Releases

Q.3.3.5 Other Release Connections

Unusual slab geometries, slabs with limited access for stressing, or slabs where even a small amount of restraint will lead to objectionable cracking may require specifically-tailored release connections. The following illustrates the common occurrence of a post-tensioned floor between two below-grade walls where there is no access for stressing at the slab edge. The plan (Fig. Q.3.3.5-1) shows stressing blockouts alternating between the two sides of the slab. The stressing blockouts are spaced so that there is about 8 ft (2.50 m) of wall support between each opening. The combination of the support from the wall and the reinforcement in the slab eliminate the need for shoring while the stressing blockout is open. Details of the stressing blockout are shown in Fig. Q.3.3.5-2.

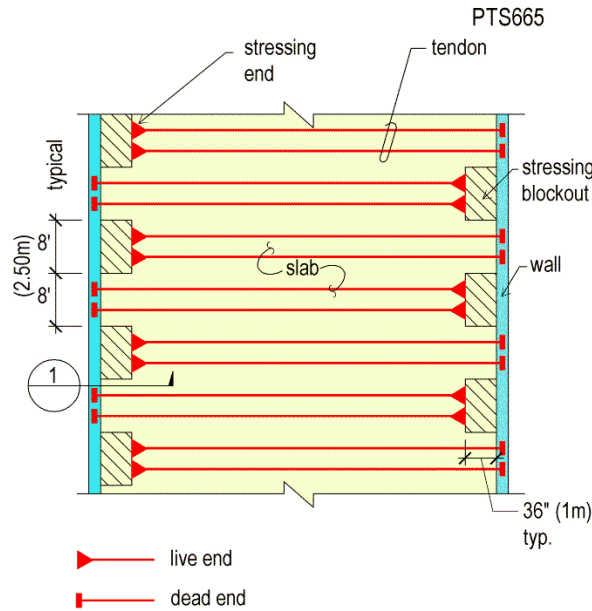

FIGURE Q.3.3.5-1 Plan; Slab between two Excavated and Shored Walls

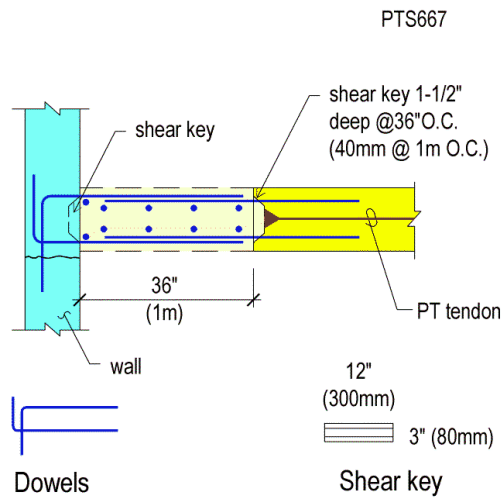

FIGURE Q.3.3.5-2 Detail of Stressing Blockout at Wall

There are many variations of slab/wall and other types of releases, each developed to suit the specific application.

Q.3.3.6 Detailing

Judicial arrangement and/or addition of post-tensioning tendons and non-prestressed reinforcement can be used to minimize the formation of restraint cracks.

A. Favorable Arrangement of Tendons: In certain conditions it is practical to arrange tendons, or to terminate them such as to either avoid significant drop in precompression, or to provide added precompression to combat stress concentration from discontinuities in the geometry of construction. The following are examples.

Figure Q.3.3.6A-1b shows an alternative arrangement of tendons around an opening to the regular straight layout. The alternative arrangement results in adding precompression to the perimeter of the opening, as opposed to causing tension by pulling apart the sides of the opening in part (a).

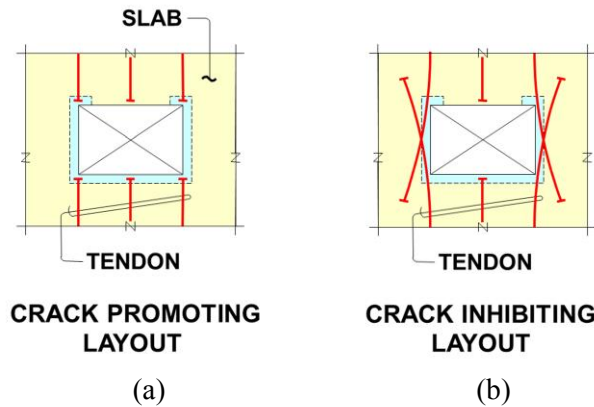

FIGURE Q.3.3.6A-1 Alternative Arrangement of Tendons around Openings (P789)

Where there are interior walls that can provide significant restraint to the free shortening of a post-tensioned slab and thus absorb some of the precompression from the tendons, overlapping of tendons as shown in the plan of Fig. Q.3.3.6-2 can be beneficial. It is emphasized that the restraint of the walls shown in the figure is of concern primarily at the lowest levels of a multistory frame. At upper levels the restraint provided by the walls is greatly reduced, and the measure shown in the figure will not be necessary (Aalami, 2014).

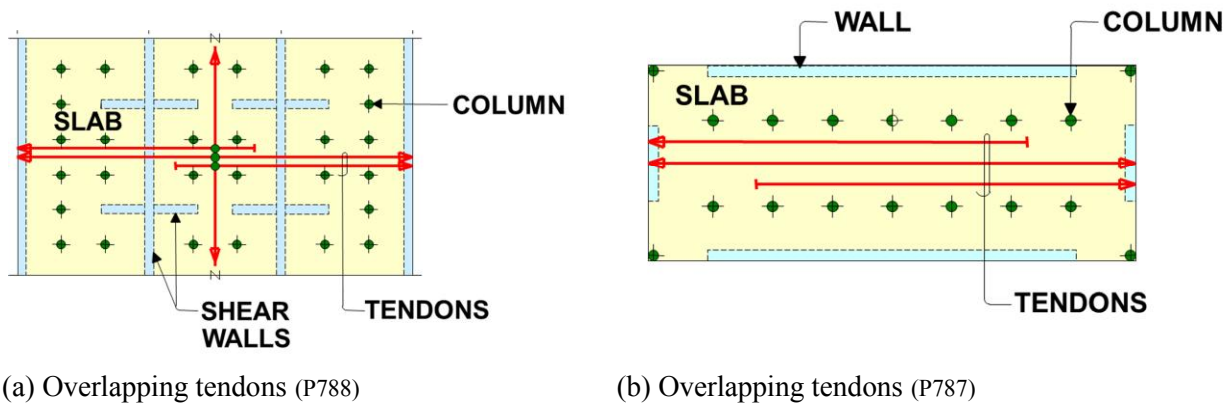
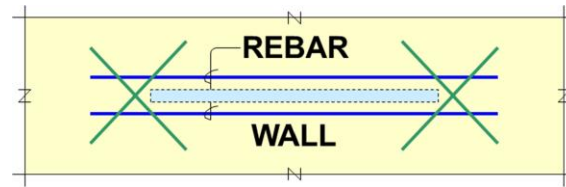
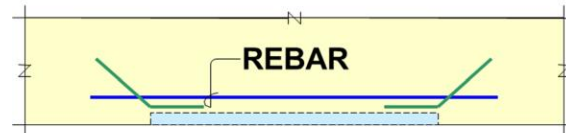

FIGURE Q.3.3.6-A2 Overlapping Tendons at the Interior Region of Slab to overcome Loss of Precompression from the Walls

B. Detailing of Non-Prestressed Reinforcement: Non-prestressed reinforcement can be used to reduce the width of cracks that result from restraint of the supports and to increase the crack in number. A single wide and long restraint crack can be reduced to a multiple short and narrow cracks to make them visually more acceptable. Two typical examples to control restraint cracks adjacent to the walls at lower levels of post-tensioned floor constructions are shown in Fig. Q.3.3.6B-1 and 2.



(a) INTERIOR SHEAR WALL



(b) EXTERIOR SHEAR WALL

FIGURE Q.3.3.6B-1 Crack Control Detailing Bars adjacent to Walls at Lower Levels of Post-Tensioned Floors (P786)

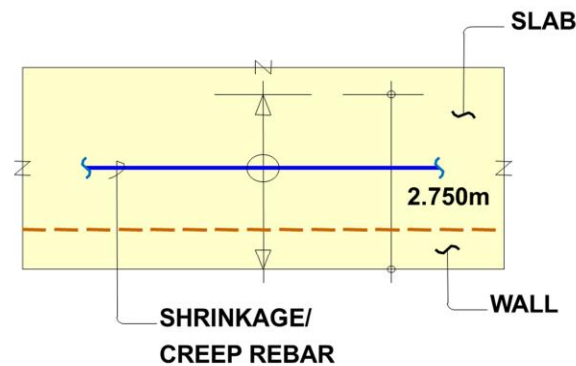

FIGURE Q.3.3.6B-2 Crack Control Detailing Bars adjacent to Continuous Walls at Lower Levels of Post-Tensioned Floors (P785)

Unlike trim bars stated above for restraint of supports to free shortening of post-tensioned floors, trim bars to control cracking at locations of stress concentration, such as opening must be used at all levels of a post-tensioned building, where a discontinuity occurs. A typical example is trim bars around openings as shown in Fig. Q.3.3.6B-3.

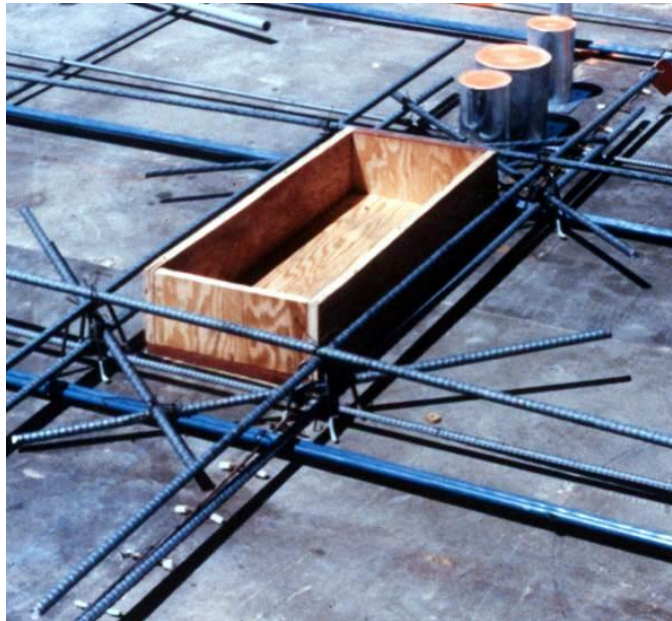

FIGURE Q.3.3.6B-3 Trim Bars around Openings (P784)

Q.4 CRACK MITIGATION EXAMPLES

In this Section, the practical aspects of design for crack mitigation design will be illustrated through two examples. The first example is a structure with a high degree of restraint requiring extensive measures to allow for the shortening of its post-tensioned floor slab. The measures and details used in this example are commonly used for similar construction in the US. The second example is the shortening calculation and crack mitigation design for a multi-story building in California.

The first step in crack mitigation is to determine the anticipated long-term shortening of the post-tensioned member. The shortening calculation is outlined in Section Q.2. In the absence of detailed computations or for preliminary designs, it is acceptable to assume 0.75 in. of shortening for every 100 ft of slab length (10 mm shortening for every 15 m of slab length). This is the value that is generally assumed for the floor slabs of residential and commercial buildings constructed in the US.

Q.4.1 Podium Slab on Perimeter Walls

A common type of residential construction in parts of California where land is expensive is to build one or two levels of parking below, or at, grade. The parking levels are constructed of post-tensioned concrete, with the slab over the top level of parking acting as a podium to support up to five levels of light framing superstructure. The light framing, in most cases, is wood construction. The floor slabs of the parking levels are usually flat slabs supported on interior columns and perimeter walls. Figure Q.4.1-1 is a typical example, where a concrete frame consisting of one level of subterranean parking and a retail level at grade, support four levels of wood frame apartment housing.



FIGURE Q.4.1-1 Apartment Building with Post-Tensioned Underground Parking and Retail at Street Level (Redwood City, CA; P791)

The plan geometry of the podium slab is as shown in Fig. Q.4.1-2. The interior columns are not shown because they do not impact the crack mitigation design.

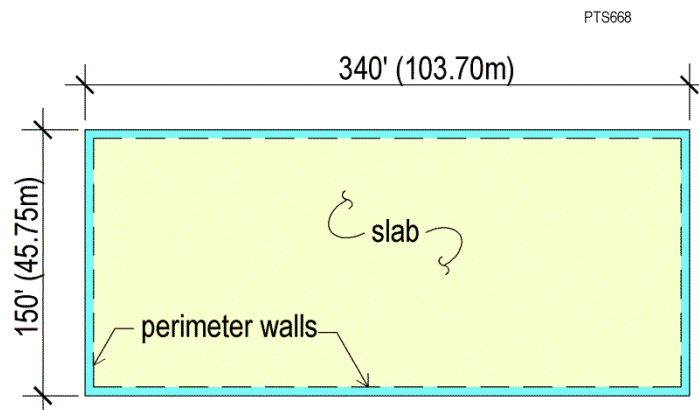

FIGURE Q.4.1-2 Plan; Overall Geometry of the Post-Tensioned Slab

The structural and construction requirements of the design are:

- ❖ Each of the long walls needs a minimum of 150 ft (45.75 m) of shear wall. This requires full connection and transfer of horizontal forces in addition to gravity between the wall and the slab.
- ❖ Each of the short walls needs a minimum of 100 ft (30.5 m) of shear walls.
- ❖ If a delay strip is provided, it may not be kept open more than a total of 20 days. This is to avoid interruption in the construction schedule.

A. Consult Crack Mitigation Guidelines: Referring to Section Q.3.1, since the length of the slab exceeds 250 ft (76 m) but is less than the length requiring a structural separation, design the slab with a central delay strip. This reduces the length that must be designed for shortening before the delay strip is closed to 170 ft (51.85 m).

Using the assumption that the long-term shortening of the slab will be 0.75 in. per 100 ft of length (10 mm per 15 m), the segments on either side of the delay strip must be designed for the following shortening:

$$\text{Total shortening at each end of each slab segment} = 170 \times 0.75 / (100 \times 2) = 0.64 \text{ in. (16 mm)} > 0.25 \text{ in. (6 mm)}$$

The anticipated long-term shortening is thus larger than what can be accommodated without crack mitigation measures.

B. Wall/Slab Full Connection Length to be Cast with Slab: At this step, we determine the maximum length of the slab/wall connection that can be cast at the same time as the slab and detailed for full shear transfer between the slab and the wall.

The maximum length of the slab (b) that can be detailed and cast with full shear transfer to the wall, while satisfying the requirement that shortening relative to the wall at any point not exceed 0.25 in. (6 mm) is:

$$b = [(2 \times 0.25) / 0.75] \times 100 = 67 \text{ ft (20.44 m)}$$

The length b is shown in Fig. Q.4.1B-1.

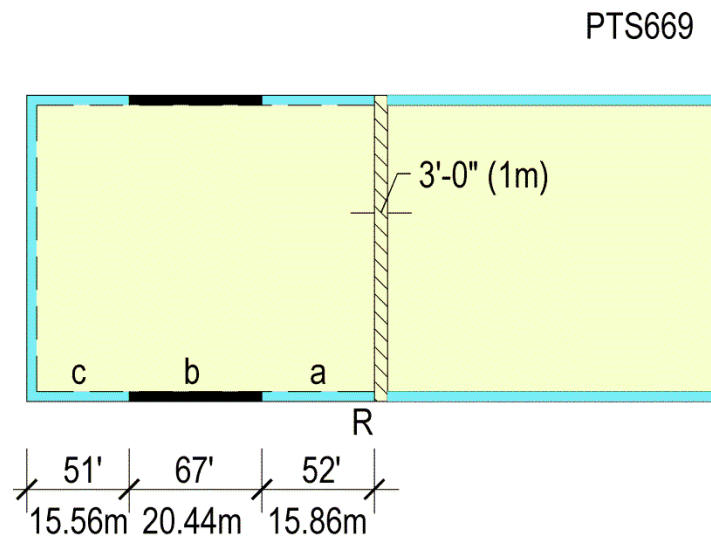

FIGURE Q.4.1B-1 Plan – Post-Tensioned Slab Partially Designed for Crack Mitigation (PTS669)

C. Determine the Position of Full Connection Length: The length (a) shown in Fig. Q.4.1B-1 is determined so as to allow the end at the delay strip (Point R) to have undergone all but 0.25 in. (6 mm) of its anticipated long-term shortening when the delay strip is cast on day 20. Once section (b) of the wall shown in Fig. Q.4.1B-1 is locked to the slab, it is assumed, for crack mitigation design, that the ends of the segment remain fixed in position. Hence, the entire shortening of the slab segment (a) will have to take place from point R at the delay strip.

Refer to Fig. Q.2.7-1 (shortening with time) to estimate the fraction of the long-term shortening that will have taken place by day 20, since at day 20 segment a will be locked to the wall and the delay strip, and further shortening will be prevented. The value read from the graph for day 20 is 36%. To ensure that no more than 0.25 in. of shortening occurs after day 20, the maximum acceptable long-term shortening of segment (a) is:

$$\text{Slab (a) total shortening} = 0.25 / (1 - 0.36) = 0.39 \text{ in. (10 mm)}$$

Using again the assumption of 0.75 in. per 100 ft (10 mm per 15 m), the distance (a) is calculated as follows:

$$a = 100(0.39 / 0.75) = 52 \text{ ft (15.85 m)}^8$$

⁸ The slight discrepancy is due to the soft conversion of 0.75" per 100' to 10 mm per 15 m

D. Verify the Adequacy of Slab to Wall Full Connection: The structural design requirements call for 150 ft (45.75 m) of shear wall connection between the slab and the wall in the long direction. The length ($b = 67$ ft; 20.44 m) calculated for the initial connection must ultimately be increased to at least 75 ft (22.88 m) on each side of the delay strip to meet the connection requirements for shear force transfer between the wall and the slab. Figure Q.4.1D-1 shows the connection at slab section (a) as a “temporary release.” A temporary release is a connection that allows relative movement between the slab and its supporting wall until the movement is prevented by establishing full fixity. A possible detail for a temporary release is shown in Fig. Q.4.1D-2. In this detail, a relatively flexible plastic pipe is initially filled with a compressible material such as compacted newspaper. To fix the connection, after the slab is cast and the anticipated shortening taken place, the compressible material is removed and the pipe is filled with high-strength grout. The floor plan shows the entire length (a) as detailed with this temporary release. Once the delay strip at the center of the floor slab is cast, both ends of the strip (a) will be prevented from shortening; in effect the entire length of strip (a) will be fixed in position when the delay strip is cast and fixity between the slab segments on the two sides of the delay strip is established.

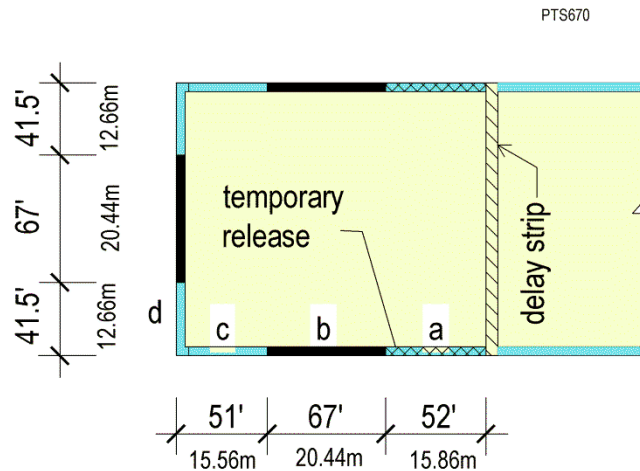
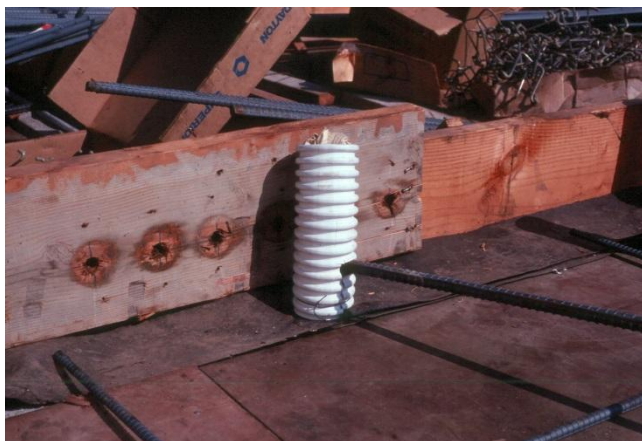
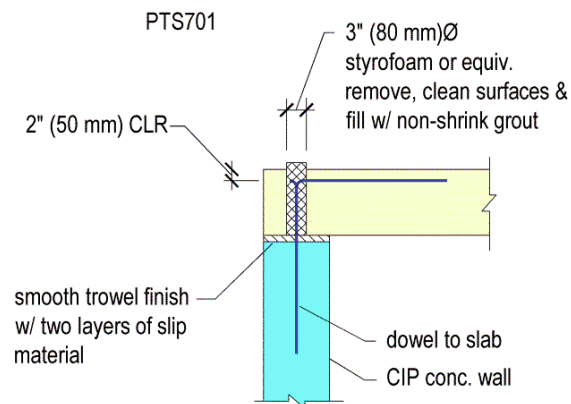

FIGURE Q.4.1D-1 Connection between Slab and wall



(a) Tube covers dowel (P773)



(b) Detail of temporary release

FIGURE Q.4.1D-2 Temporary Release Connection between Slab and Wall
Top of wall is finished with two layers of slip material

E. Detail the Remainder of Slab/Wall Supports: Since section (c) of the slab is almost the same length as section (a), it is assumed that sufficient shortening will have taken place by day 20 that the slab section can be locked to the wall at that point. In practice, however, for improved crack mitigation, it is better to leave any connection that is not required by design to be fixed as a “permanent release.” The release at slab corners avoids the formation of cracks shown in Fig. Q.4.1E-1. As shown in Fig. Q.4.1E-2, a length of 10 ft (3 m) is often left as a permanent release at the corners. In this example, because of the long length of the slab, a length of 20 ft (6.1 m) is detailed as a permanent release. Figure Q.4.1E-3 is an example of a permanent release at a slab corner, where two sheet layers of manufactured woods are used to separate the slab from the wall and allow the slab to move with respect to the wall. The remainder of segment *c* is designated as a temporary release.

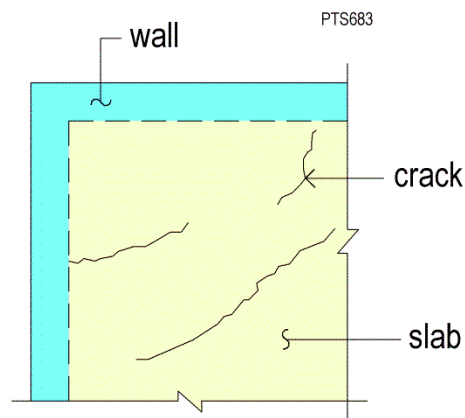

FIGURE Q.4.1E-1 Cracking at Restrained Corners of Post-Tensioned Floors

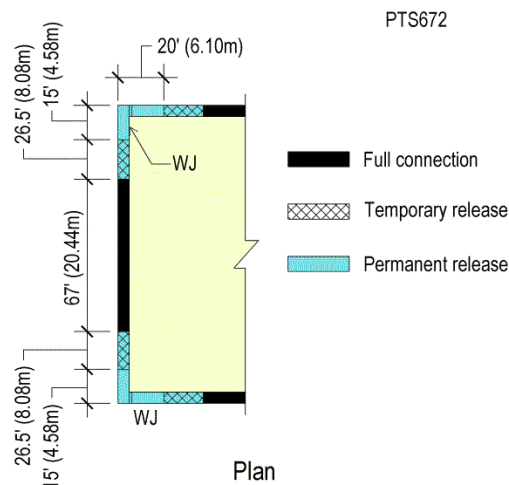
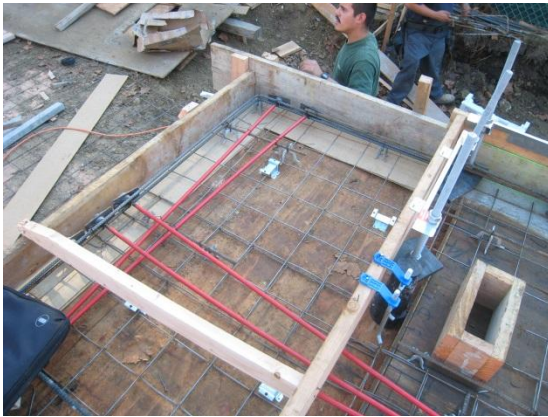

FIGURE Q.4.1E-2 Slab/Wall Connection Plan (PTS671)



(a) Permanent release at slab corner, showing two layers of slip sheet on top of wall (P809)



(b) Manufactures sheets used for slip join (P775)

Q.4.1E-3 Detail of Permanent Slab/Wall Release Showing the Installation of Slip Material as Slab Corner

F. Design of the Short Wall Connection: From the design for the long direction it was determined that 67 ft (20.44 m) of full connection between the wall and the slab can take place at the time the slab is cast. For the short wall, the balance of the required length for 100 ft (30.5 m) of full connection results in:

$$\text{Required full connection at each end} = (100 - 67)/2 = 16.5 \text{ ft (5.03 m)}$$

Thus, it will be necessary to provide a temporary release over a 16.5 ft (5.03 m) length of slab at each end of the full connection. The connection can be locked on day 20 when the delay strip is cast.

G. Review of Detailing: Recognizing that the procedure is highly empirical and derived from the practice of design engineers in the field, once the computations are completed, engineering judgment is exercised to conclude the design with practical construction details. When finalizing the details, attention is paid to irregularities in the geometry of the slab and its supports, including interior wall connections, such as commonly exist at elevators and stair wells.

The final detailing of the connections is shown in Fig. Q.4.1G-1, where a permanent release of 15 ft (4.58 m) is considered adequate for the short wall. Where a permanent release is intended, the top of the wall must be trowel finished to a smooth surface and then covered with a slip material. The slip material often used is two layers cut from sheets of $\frac{1}{4}$ -in. (6 mm) manufactured wood⁹. The sheets are smooth on one face (Fig. Q.4.1E-3); the smooth sides are placed face to face, to allow free movement between the two sheets. The advantage of this material is that it is stiff enough to bridge over small irregularities, in case the top of the wall is not adequately smooth.

⁹ Trade name “Masonite”

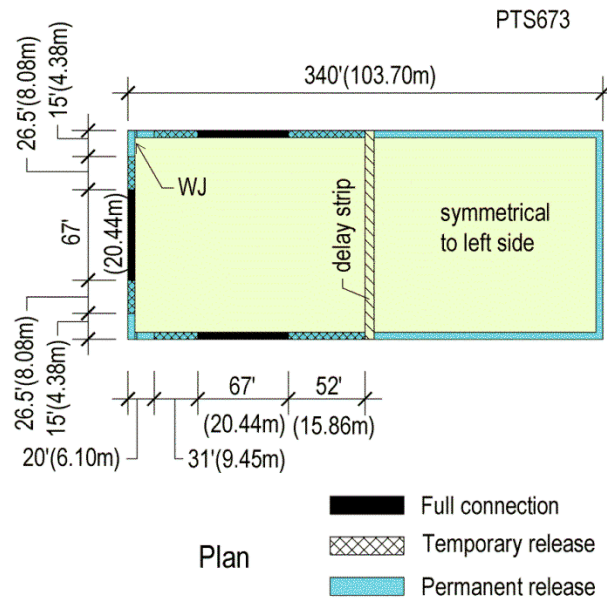

FIGURE Q.4.1G-1 Completed Design of the Crack Mitigation Scheme

Where practical the intersecting wall corners are provided with a wall joint (marked WJ on Fig. Q.4.1G-1) that has a gap of about $\frac{3}{4}$ in. (20 mm). The wall joint is intended to provide the short wall greater freedom to bend out of its plane in following the shortening of the slab. Figure Q.4.1G-3 shows a wall joint along with a wall/slab joint provided with slip material. A view of the slip strips on top of the wall prior to casting the slab is shown in Fig. Q.4.1E-3.



(a) Wall joint as support corner (P778)



(b) Wall/slab connection with slip layers (P779)

FIGURE Q.4.1G-3 Wall Joint and Slab/Wall Connection with Slip Material (show picture before concrete is poured)

Q.4.2 Example of a Multistory Building

Construction of post-tensioned multi-story buildings fall in the category of “phased construction,” also referred to as “Segmental Construction,” where the structural members are installed and placed in service one after the other. Further, during the construction, previously installed members will be subject to loads, stresses, and deformations that impact the response of the completed structure to its in-service design load. The “phased construction” analysis of concrete structures

with detailed consideration of long-term effects is well understood and coded in commercially available software¹⁰. However, for practical design of common residential and commercial buildings, empirical and approximate schemes can be used to account for the shortening of the floor slabs from post-tensioning and the restraint of the supports to the shortening.

These empirical methods have been validated by the satisfactory performance of buildings where they have been used. To a great extent, however, the successful application of these methods rests on the experience and the engineering judgment of the designer.

The factors causing shortening of a floor slab and the calculation of this shortening are detailed in Section Q.2. The assumptions and procedures to account and allow for the shortening are discussed in Sections Q.2 and Q.3, followed by a numerical example for a single level structure. When dealing with multistory buildings, in addition to the assumption that 0.25 in. (6 mm) of shortening is acceptable, the following assumptions are made.

At the first elevated floor, the shear walls are assumed to be fixed to the foundation. At the upper levels of a multistory building, the shear walls are more elastic as they are less restrained by the foundation. The walls thus provide less restraint to slab shortening. Table Q.4.2-1 can be used to obtain an initial estimate of the shortening that can be accommodated by the upper levels of a multistory building. The table distinguishes between single walls and compound walls such as T-shaped, U-shaped, or core walls.

Using the table, at the 4th elevated level and above, single walls are assumed to provide no restraint to the shortening of the floor slab. Referring to the table again, at the third elevated level above the foundation, for a “core wall”, it is assumed that the long-term movement accommodated by the wall at the wall/slab connection is 3 mm (0.12 in.). If the “calculated” floor shortening at this level is 8 mm (0.31 in.), the amount of shortening that needs to be designed for is 5 mm (8 – 3 = 5 mm; 0.2 inch). Since the slab is assumed to be able to accommodate a larger amount of shortening, namely, 6 mm (0.25 in.), no crack mitigation measures will be necessary.

The values in Table Q.4.2-1 are for construction where each level of the wall is cast right after the slab below is cast. When core walls such as those for the elevator shafts are constructed several levels above the floors, lower values should be assumed for the amount of slab shortening that the walls can accommodate, as the walls will have undergone some amount of shrinkage before the slabs are cast. In addition, core walls are generally in the shape of C, U or a box. Compared to single walls, core walls provide a larger restraint to the horizontal movement that could accommodate slab shortening.

TABLE Q.4.2-1 The Amount of Shortening Accommodated by Walls that Support Post-Tensioned Floors (T189)

Level	Single walls	Core/ compound wall
1 st level	0	0
2 nd level	0.125 in. (3 mm)	0.06 in. (2 mm)
3 rd level	0.25 in. (6 mm)	0.12 in. (3 mm)
4 th level	No restraint	0.18 in. (5 mm)
5 th level	No restraint	0.25 in. (6 mm)
6 th level	No restraint	No restraint

¹⁰ ADAPT-ABI www.adaptsoft.com

A. Project Description: The project is a 14-level building in California, consisting of ten hotel floors topped by four floors of residential units (Fig. Q.4.2A-1). The overall geometry of the building's floor plan is shown in Fig. Q.4.2A-2. The floor slabs are post-tensioned and supported on interior columns. The lateral force resisting system of the building consists of two thick and heavily-reinforced shear walls at each end of the long, narrow building. Each shear wall is shaped to provide resistance in both directions. The unfavorable position of the shear walls at the ends of the building made crack mitigation an essential part of the design process.



FIGURE Q.4.2A-1 – Elevation of the Building

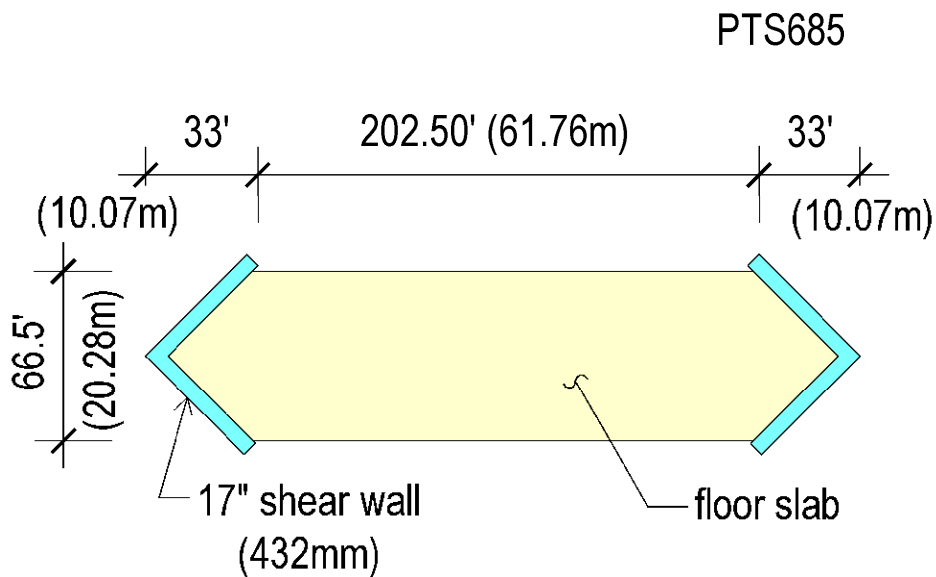

FIGURE Q.4.2A-2 – Plan; Schematic of Typical Level. Tendons Run in both Directions (not shown)

B. Long-Term Shortening of Typical Floor: The design length of the floor slab is taken as 202.50 ft (61.76 m) plus one half of the length encompassed by the end walls.

Design length of the slab in the long direction = $202.50 + 33 = 235.5$ ft, rounded to 235 ft (71.68 m)

In the short direction, the design length is 66.50 ft (20.28 m)

From the calculations detailed in Section H, the anticipated shortening of a typical level of the building in the long direction is estimated as 1.38 in. (35 mm)¹¹.

Anticipated shortening at each end = $1.38/2 = 0.69$ in. > 0.25 in. (17.5 mm > 6 mm),

Hence design for crack mitigation is required.

C. Crack Mitigation for Typical Floor: The construction schematic and schedule of construction for a typical 7-day cycle of upper level floors is shown in Fig. Q.4.2C-1 and listed in Table Q.4.2C-1. A typical floor level (*i*), as indicated in the figure will be locked to the remainder of construction at stage 6 of each cycle, when the additional shortening of the locked slab will be restrained.

Each slab is tied to the shear wall through its dowel connection with the wall above it (Fig. Q.4.2C-1). From the schedule of construction shown in figure and listed in the table, the time lapse between locking the movement of a freshly cast floor to the wall below it is five days. The construction detail shown in the figure allows the slab to shorten freely within this 5-day period.

In multi-story buildings such as the current project, as a floor slab shortens, it draws the walls that it is tied to with it. Based on the sequence and schedule of construction given above, the following observations are made:

- ❖ The movement of each cast slab is locked to the structure after five days through the slab connection with the wall above.
 - ❖ When a floor slab is locked to the walls above it, the slab and the wall above rest on the wall immediately below. The newly cast slab and the wall above will be subject to the long-term movement of the wall below to which they are locked. Following the schedule of construction, one arrives at the conclusion that on the day the current slab (level *i*) is locked to the remainder of the construction through its dowels to the wall above, the floor slab at the level below (level *i-1*) is 12 days old.
 - ❖ The newly cast slab will continue to shorten. The wall that supports this slab is tied to the slab of the level below that will also continue to shorten, albeit with a seven day ($12-5 = 7$) time gap.
- ❖ The long-term anticipated differential shortening of a floor slab and the slab immediately above and below is the difference between the shortening that takes place between days 5 and 12. This is the shortening that will be resisted by the restraint of the shear walls at the ends of the building and is subject to design for crack mitigation.

From long-term shortening graph Q.2.7-1:

¹¹ In the absence of detailed calculation followed here, the estimated shortening would be $235.5 \times 0.75 / 100 = 1.75$ in. (44 mm)

The fraction of the long-term shortening that has taken place by day 12 is 28 %

The fraction of the long-term shortening that taken place by day 7 is 16 %

The restraint of the end walls to the slab shortening thus corresponds to $(28 - 16) = 12$ % of the calculated long-term shortening.

This amounts to $0.12 \times 0.69 = 0.08$ in. (2 mm) < 0.25 in. (6 mm) OK

Since the shortening that will take place after the slab has been tied to the supports is less than 0.25 in. (6 mm), no crack mitigation measures are necessary for the typical upper levels of the building. The above conclusion is based on the premise of the empirical Table Q.4.2-1, from which the walls at the upper levels do not require to be designed for restraint of supports. The restraint design carried out was based on the differential shortening between adjacent levels.

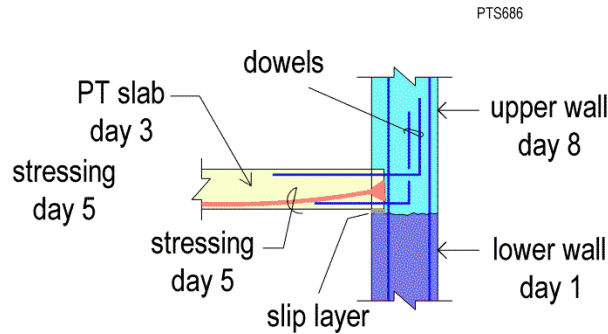

FIGURE Q.4.2C-1 Section; Slab-Wall Connection Detail; Construction Sequence and Schedule

TABLE Q.4.2C-1 Construction Schedule (T190)

Stage	Day	Operation
1	1	Cast wall for upper slab support
2	2	Finish forming of slab (<i>i</i>) above and place reinforcement
3	3	Cast slab (<i>i</i>)
4	5	Stress tendons of slab (<i>i</i>)
5	6,7	Form slab of level above (<i>i</i> +1) and upper walls
6	8	Cast upper walls (<i>i</i> +1)
7	9	Finish forming of slab (<i>i</i> +1) above and place reinforcement
8	10	Cast slab (<i>i</i> +1)
9	12	Stress tendons of slab (<i>i</i>)
10	13,14	Form slab of level above (<i>i</i> +2) and upper walls
11	15	Cast upper walls (<i>i</i> +2)

D. Crack Mitigation Design of the First Elevated Floor: D. Crack Mitigation Design of the First Elevated Floor:

Referring to the estimate of the long-term shortening of the typical level, the anticipated shortening of the first floor will be the same — 1.38 in. (35 mm). From Table Q.4.2-1, it is assumed that the walls at the first elevated slab are completely rigid and will not accommodate any shortening. Because of the amount of anticipated shortening, it will be necessary to provide delay strips at both shear walls as well as at the center of the slab. This will allow the shrinkage to occur at both ends of each slab segment. The tendons in each slab segment will be short enough that they only have to be stressed at one end. The delay strip at the center should be wide enough to allow for stressing (Fig. Q.4.2D-1); the delay strips at the shear walls do not have to be designed for stressing (Fig. Q.4.2D-2). Contrary to what is shown in Fig. Q.4.2D-1a, the delay strip at the connection with the end wall can be narrower as shown in part (b) of the figure.

Total long-term shortening at each end of each slab segment = $1.38/4 = 0.35$ in. (9 mm)

Since the slab is assumed to be able to accommodate 0.25 in. (6 mm) of shortening, the amount of shortening that must take place freely (before the delay strips are filled) is calculated as follows:

Shortening to take place = $0.35 - 0.25 = 0.1$ in. (2.5 mm)

Fraction of total shortening to take place freely is: $0.1/0.35 = 0.28 = 28\%$

Referring to Fig. Q.2.7-1, this corresponds to 40 days. Hence, at the first elevated level, the delay strips should be left open for 40 days.



(a) Detail of delay strip at connection to wall. There is a gap between the end face of the wall and slab (P792)

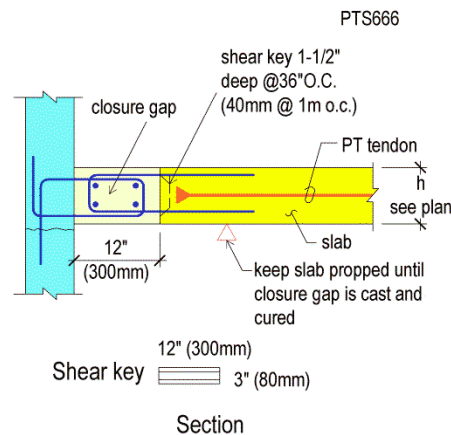

(b) Delay strip at wall with no stressing

FIGURE Q.4.2D-1 Delay Strip at Wall. (The gap at the face of the wall in part (a) can be narrower when tendons will not be stressed at the delay strip)

E. Crack Mitigation of Second Elevated Floor: The long-term shortening of the second elevated floor slab in the long direction will be the same as the typical level - 1.38 in. (35 mm). If the slab is divided into halves like the first elevated floor, the unrestrained shortening of each half will be:

Total shortening at each end of each slab segment = $1.38/4 = 0.35$ in. > 0.25 in. (9 mm $>$ 6 mm)

From Table Q.4.2-1, the connection of the wall to the slab at this level is assumed to accommodate 0.125 in. (3 mm).

The balance of the shortening will be: $0.35 - 0.125 = 0.225$ in. < 0.25 in. (approx. 6 mm) OK

Since at the connection to the wall, the remainder of the computed shortening is less than 0.24 in. (6 mm), the same detail and stressing schedule as used for the typical level can be adopted. Note that at this level, the provision of a central slip joint at the middle of slab (Fig. Q.4.2.E-1) reduces the shortening that needs to be allowed at the wall/slab connection. Thus enabling the same detail as in typical levels to be used.

Details of the permanent release used at the center of the floor slab is shown in Fig. Q.4.2.E-1.

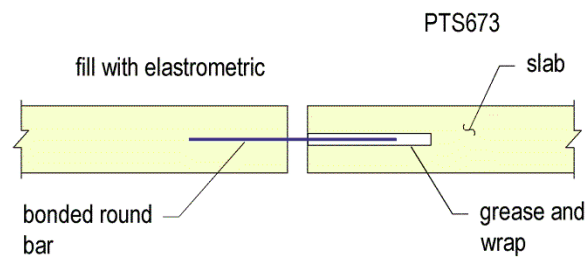

(a) Section: Permanent Release in Slab



(b) Permanent Slab Release
Figure Q.4.2E-1

F. Crack Mitigation of Third Elevated Floor: The third elevated floor is detailed as a typical level.

G. Comments on the Adopted Mitigation Scheme: A section view of the structure with the crack mitigation detailing is shown in Fig. Q.4.2G-1. Recognizing that the methods used to design the crack mitigation scheme are highly empirical, engineering judgment must be used to adjust the design, taking into account both irregularities in the geometry of the slab and construction requirements.

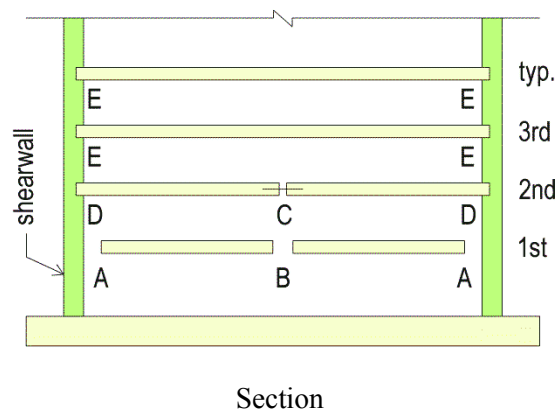

Figure Legend: A: Q.4.2D-2; B: Q.4.2D-1; C:Q.4.2E-1;D and E: Q.4.2C-1.

FIGURE Q.4.2G-1 Partial Section of Building

H. Computation of Unrestrained Shortening of Typical Floor: Using the procedure outlined in Q.2, the unrestrained shortening of a typical level is calculated as follows:

Design Parameters

Concrete strength, $f'_c = 6000$ psi (41 MPa)

Concrete strength at stressing, $f'_{ci} = 3000$ psi (20.7 MPa)

Relative humidity, $H = 70\%$

Slab thickness = 7 in (178 mm)

Seasonal change in temperature = 35 F° (19 C°)

P/A , longitudinal direction = 125 psi (0.86 MPa)

P/A , transverse direction = 150 psi (1.00 MPa)

Shortening Calculations:

❖ Elastic shortening strain, ES :

$$ES = (P/A) / E_{ci}$$

$$E_{ci} = 33 \times 150^{1.5} \sqrt{3000} = 3,320,560 \text{ psi (22,895 MPa)}$$

In SI units the calculation is :

$$E_{ci} = 0.043 \times 2400^{1.5} \sqrt{20.7} = 23,002 \text{ MPa}$$

Hence, the elastic shortening strain of the slab ES is:

$$\text{For longitudinal direction } ES = (125/3320560) = 38 \times 10^{-6}$$

$$\text{For transverse direction } ES = (150/3320560) = 45 \times 10^{-6}$$

❖ Shrinkage shortening strain, *SH*:

$$SH = SH_0 \times k_{RH} \times k_{v/s}$$

SH_0 = applicable base shrinkage strain = 510 micro-strains

Correction for relative humidity $H = 70\%$.

$$k_{RH} \text{ for } 70\% = 1.00$$

Correction for volume to surface ratio:

$$V/S = 0.5 \times 7 = 3.5 \text{ inch (0.5} \times 178 = 89 \text{ mm)}$$

The correction factor $k_{v/s}$ is:

$$k_{v/s} = [1064 - 94 \times 3.5] / 923 = 0.80 \quad \text{US units (inch)}$$

$$k_{v/s} = [1064 - 3.7 \times 89] / 923 = 0.80 \quad \text{SI units (mm)}$$

Hence the long-term shrinkage strain is:

$$SH = 510 \times 10^{-6} \times 1.00 \times 0.80 = 408 \times 10^{-6}$$

❖ Creep shortening strain, *CR*:

$$CR_c = CR_0 \times K(PT) \times k_f \times k_{cRH} \times k_c$$

CR_0 = applicable base creep coefficient = 2.0

Correction for concrete strength $k_f, f'_c = 6000 \text{ psi (41 MPa)}$

$$k_f = 1 / (0.67 + 6/9) = 0.75 \quad \text{(US units)}$$

$$k_f = 62 / (42 + 41) = 0.75 \quad \text{(SI units)}$$

Correction for relative humidity

$$k_{cRH} = (1.58 - H/120)$$

$$k_{cRH} = (1.58 - 70/120) = 1.00$$

Correction for volume to surface ratio:

$$V/S = 0.5 \times 7 = 3.5 \text{ inch (0.5} \times 178 = 89 \text{ mm)}$$

The correction factor k_c is:

$$k_c = \left[\frac{1.80 + 1.77 e^{-0.54 \times 3.5}}{2.587} \right] = 0.80 \quad \text{US units}$$

$$k_c = \left[\frac{1.80 + 1.77e^{-0.0213 \times 89}}{2.587} \right] = 0.80 \quad \text{SI units}$$

Having obtained the correction factors, the creep coefficient is given by:

$$CR_c = 2.0 \times 0.75 \times 1.00 \times 0.80 = 1.20$$

$$\text{For the longitudinal direction, the creep strain, } CR = CR_c \times ES = 1.20 \times 38 \times 10^{-6} = 46 \times 10^{-6}$$

$$\text{For the transverse direction, the creep strain } CR = CR_c \times ES = 1.20 \times 45 \times 10^{-6} = 54 \times 10^{-6}$$

❖ Strain due to seasonal change in temperature:

$$TEMP = T \times \alpha$$

$$TEMP = 35 \times 6.0 \times 10^{-6} = 210 \times 10^{-6}$$

❖ Total shortening strains, not accounting for seasonal change in temperature:

$$a = L (ES + SH + CR + TEMP)$$

In the longitudinal direction:

$$S = (38 + 408 + 46 + 210) \times 10^{-6} = 702 \text{ micro-strains}$$

In the transverse direction:

$$S = (45 + 408 + 54 + 210) \times 10^{-6} = 717 \text{ micro-strains}$$

❖ Shortening, a , not including temperature effects :

In the longitudinal direction:

$$\text{average length} = 235 \text{ ft (71.6 m)}$$

Total shortening strain

$$S = 38 + 408 + 46 = 492 \text{ micro-strain}$$

$$\text{Shortening, } a = 492 \times 10^{-6} \times 235 \times 12 = 1.38 \text{ in (35 mm)}$$

R.1 IMPACT OF SUPPORT RESTRAINT ON FLOOR SAFETY

Apart from the adverse impact of support restraint on the in-service performance of a floor slab [TN454, 2015], the restraint also influences the safety of post-tensioned members. This is more pronounced where the restraint leads to cracking. The following reviews the impact of the support restraint on the safety of post-tensioned members.

R.1.1 Restraint Cracks and Safety

Post-tensioning in floor slabs is generally designed to provide:

- ❖ Precompression;
- ❖ uplift; and
- ❖ added strength.

The focus of the following is the contribution of post-tensioning to the strength of a post-tension member. Figure R.1.1-1 illustrates the mechanism by which post-tensioning tendons contribute to the strength of a member in the absence of support restraints. This will be contrasted to the case in Fig. R.1.1-2 – where the member is subject to support restraints.

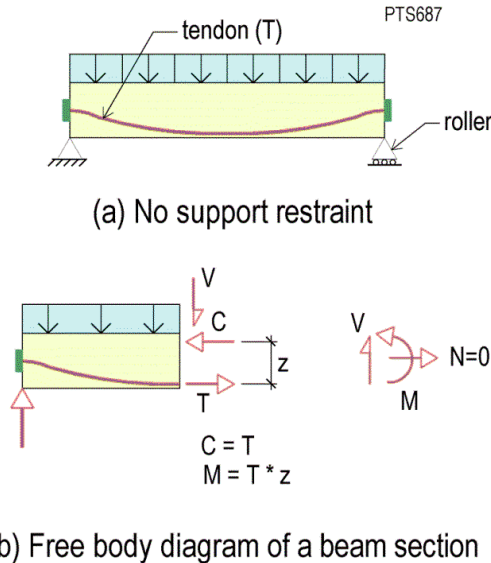

FIGURE R.1.1-1 Post-Tensioned Member with no Support Restraint to Shortening

For the member shown in Fig. R.1.1-1, the strength demand at a section (part b) consists of: moment (M), shear (V) and axial force (N). The demand actions M , V and N are in static equilibrium with the forces acting on the severed segment of the member. For the safety of the structure, the resistance than can develop at the face of the cut by the forces T , C and V should not be less than the demand actions M , V and N .

Since the member is on rollers, the reaction at the support (part b of the figure) is limited to a vertical force. There are no externally applied horizontal forces on the cut segment. From the equilibrium of the forces, the net axial force on the face of the cut will be zero ($N = 0$). Hence, the resisting forces need to counteract the moment, M and shear force, V only.

The resistance to the demand moment M at the section is developed by the tendon force T and the compression force C in the concrete:

$$T = C \quad (\text{Exp R.1.1-1})$$

$$M = Tz \quad (\text{Exp R.1.1-2})$$

Where z is the moment arm of the forces at the face of the cut. In this case, where there is no restraint to shortening from the supports, the entire tendon force T is available to resist the demand moment M .

Consider now the case shown in Figure R.1.1-2, where a post-tensioned member is attached to supports that restrain the member's shortening. In this figure, and the figures in sub-sections R.1.3 the following definitions are made:

F = force in the tendon at ultimate limit state (strength condition);

F_2 = force in the tendon in service condition; and
 F_3 = restraint of support in service condition.

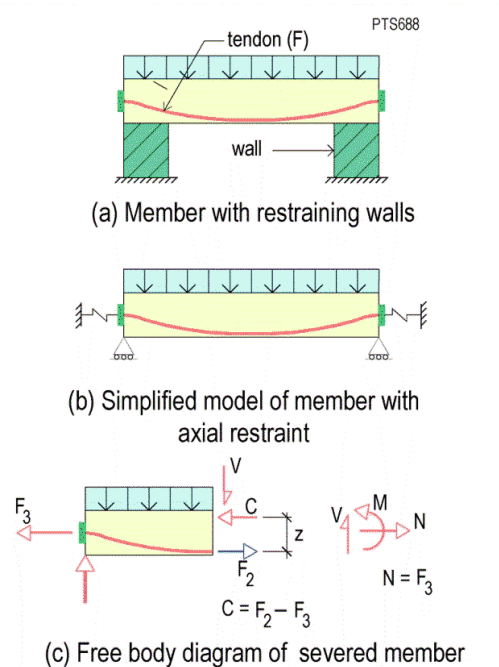

FIGURE R.1.1-2 Post-Tensioned Member with Support Restraint

At tendon stressing the supports shown absorb a part of the post-tensioning force, marked F_3 in part (c) of the figure. The amount of the force F_3 that is diverted to the supports depends on the stiffness of the supports; the remainder of the post-tensioning force results in precompression in the member. For ease of visualization, the member is modeled as shown in part (b). The springs attached at each end of the member represent the restraint of the supports to the shortening of the member.¹²

The discussion followed for the member in Fig. R.1.1-1 will be used here to determine the contribution of the tendon force to the safety of the member. Part (c) of Fig. R.1.1-2 is the free body diagram of the left segment of the member. The demand actions at the face of the cut are once more the moment M , shear V , and axial force N . In this case, however, from the equilibrium of the forces in the horizontal direction we have:

$$N = F_3 \quad (\text{Exp R.1.1-3})$$

Thus, in addition to the moment M and shear V , there is a net axial tension F_3 that must be resisted by the actions developed at the face of the cut. From the equilibrium of the forces on the segment:

$$C = F_2 - F_3 \quad (\text{Exp R.1.1-4})$$

¹² There will also be a moment at the end of the member due to the shift of the restraining force (F_3) at the support from the support/member interface to the centroid of the member shown in part (b). This moment is not shown in the figure, since its presence does not impact the current discussion.

Hence, the resisting moment at the face of the cut will be:

$$M \simeq F_2 z - F_3 e \quad (\text{Exp R.1.1-5})$$

Where e is the distance between the force F_3 and the centroid of the compression force C . The approximation sign (\simeq) is used, since the force F_3 acts at the interface between the support and the member, but for the current discussion, it is shown at the centroid of the member, with the restraint modeled as a spring.

In summary, when a member is restrained at supports, the post-tensioning force available to resist the demand moment M is reduced. The amount of reduction, in this example F_3 , depends on the stiffness of the restraining supports.

The preceding is a simplification of the mechanism for development of resistance in a post-tensioned member, intended to present the concept. With increase in applied load, there will be an increase in tendon strain, which in turn results in an increase in tendon force. At ultimate limit state, the force in the tendon (F) is thus $F_2 + \Delta F_2$, where ΔF_2 is the increase in tendon force due to local strain. The amount of the increase depends on whether the tendon is bonded or unbonded. For bonded tendons, the increase is local and can bring the tendon's stress to its ultimate strength (f_{pu}). For unbonded tendons the increase is typically considerably less.

To illustrate the concept, in the following the extreme condition of large support restraint is examined. In this condition, the entire post-tensioning is diverted to the supports, leading to cracks through the depth of a member. Non-prestressed reinforcement helps to control crack width and crack dispersion. To highlight the interaction of prestressing and the restraint of the supports, in the following the contribution of non-prestressed reinforcement is not accounted for.

R.1.2 Unbonded Tendons; Safety and Restraint Cracks

R.1.2-1 shows a member reinforced with unbonded tendons with a single crack that extends through the depth of the section (part a). The crack is from shrinkage of concrete and the full restraint of the supports A and B to free shortening of the member. Supports C and D are shown as roller supports.

For simplicity, tendons are shown along a straight line; selfweight and external loads are not shown. Note that in part (a) of the figure, the tendon retains its force (F_2) across the cracked section, but there is no compressive force on the face of the crack, since the member is assumed fully fixed against shortening at its end supports. The entire tendon force is diverted to the support A.

An idealized free body diagram of the left segment of the member for the post-tensioning forces is shown in part (b). The restraint from the supports, F_3 is equal to , the force in the tendon (F_2) .

With increase in the applied load, the member will develop hinge lines at the locations marked in Fig. R.1.2-2b. The downward displacement of the slab prior to collapse will elongate the tendons along their length, resulting in an increase (δF_2) in the tendon force. The initial tendon force at location of through crack under service condition (F_2) will increase to its final value F as shown in part (c) of the figure. The impending failure mechanism re-establishes contact between the two sides of the crack, where a compressive force C will develop. For unbonded tendons, the increase in tendon force

across the crack prior to failure will be partially transferred to the supports A and B ¹³ because although the member itself is restrained against movement, the tendon can slide within its sheathing. At the ultimate state, the restraint from the supports increases to F_4 .

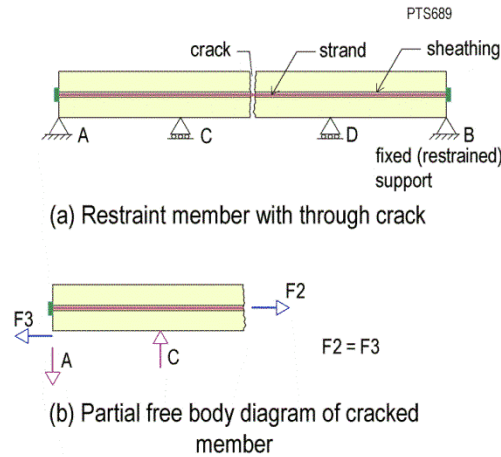

FIGURE R.1.2-1 Post-Tensioned Member with through Crack Caused by Restraint of Supports

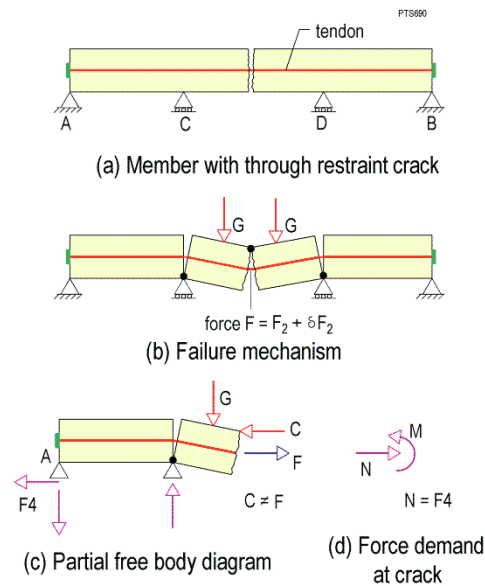

FIGURE R.1.2-2 Failure Mechanism and Partial Force Diagram of Member with Through Crack

The force demand (design values) at the crack will be the axial tension N and moment M shown in part (d) of the figure¹⁴. The axial tension N equals F_4 , the restraint of the support at point A at Ultimate Limit State.

¹³ If the member length is longer than is common in building construction, the increase in tendon force can be absorbed by the increase in friction, but this seldom occurs in practical conditions.

¹⁴ There will also be a shear force at the section from the applied loads. Since the focus is on the evaluation of the moment capacity, for simplicity of presentation the shear force is not shown in the free-body diagram.

The demand actions F_4 and M at the cracked section are resisted by the increase in tendon force across the crack resulting from the displacement of the member and the compressive force (C) developed at the newly established area of contact. The relationships are:

$$C = F - F_4 \quad (\text{Exp R.1.1-6})$$

$$M = C z, \quad (\text{Exp R.1.1-7})$$

Where z is the lever arm between the centroids of the tension and compression forces, and F is the force in the tendon at the crack. The tensile force in the tendon that contributes to the resistance capacity of the cracked section is the difference between the force in the tendon at the crack (F) and the restraint of the support (F_4).

The partial free body diagram of the horizontal forces for the left segment of the member is shown in Fig. R.1.2-3. The figure shows the contribution of the friction forces (P) between a strand and its sheathing in developing the compression force (C). It is noted that the compressive force C that can be developed across the crack prior to the collapse of the member is limited to the friction force (P) that builds up between a strand and its sheathing (part b of the Figure). This is based on the initial premise that the support restraint at A is large enough to prevent the shortening of the member.

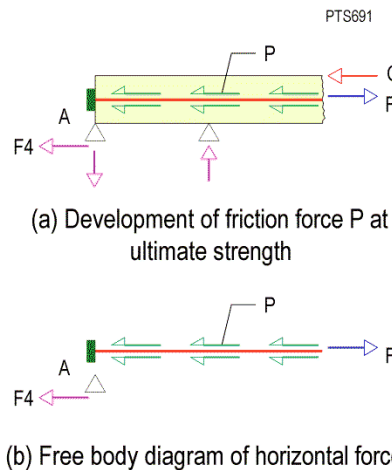

FIGURE R.1.2-3 Development of Friction Force P at Ultimate Strength

From part (b) of the figure:

$$P = F - F_4 \quad (\text{Exp R.1.1-8})$$

From part (a) of the figure:

$$C = F - F_4 \quad (\text{Exp R.1.1-9})$$

Where F_4 is the restraint from the support at the ultimate limit state. Therefore,

$$C = P \quad (\text{Exp R.1.1-10})$$

To arrive at the upper bound for the moment that can possibly develop at the crack, the tendon is assumed to be stretched to its rupture force, recognizing that this is impractical for unbonded tendons, before a member can be considered “failed.”

The force F in the tendon is calculated as:

$$F = A_{ps} f_{pu} \quad (\text{Exp R.1.1-11})$$

Where A_{ps} is the tendon cross-sectional area and f_{pu} ¹⁵ is its specified strand strength (commonly 270 ksi; 1860 MPa). The tendon force F will decrease along the tendon length due to friction between the tendon and its sheathing. For a given tendon profile and friction coefficients, the stress loss due to friction can be calculated with the following equation:

$$P_x = P_j e^{-(\mu\alpha + Kx)} \quad (\text{Exp R.1.1-12})$$

Where,

- P_x = stress in tendon at distance x from the point of application of force to tendon;
- P_j = stress in tendon at the point of application of force;
- μ = coefficient of angular friction (/radian);
- α = total angle change of the strand in radians from the stressing point to distance x ;
- x = distance from the stressing point; and
- K = coefficient of wobble friction (/ft¹⁶; /m).

Once the friction force P and hence the compressive force C across the crack are determined, the design capacity of the section is known. Note that in an actual structure, the contribution of the non-prestressed steel across the crack must be included in the calculations; the compressive force C will be resisted by both the tendons and the non-prestressed reinforcement. The capacity of the section will depend on the location and the magnitude of the tendon force and the location and amount of the non-prestressed reinforcement.

In the general case, a restraint crack is likely to break the member into two non-equal lengths as illustrated in Fig. R.1.2.-4. For static equilibrium of the member, the restraining forces (F_4) on each side of the crack must be equal. Thus the friction force (P) that can be sustained across the crack is that from the segment with the smaller friction loss – typically the shorter side of the member. Concluding with $C = P$, the moment capacity is:

$$M = Pz \quad (\text{Exp R.1.1-13})$$

In summary, the maximum tensile force that will be available to develop a resisting moment at the crack is limited to the friction that develops between the tendon and its sheathing at ultimate limit state. This is further illustrated in Fig. R.1.2-5. In this Figure $F_2 = F_3$ is the in-service tendon force at the location of through crack prior to the application of added load and establishment of the compression force C (refer to Fig. R.1.2-1).

¹⁵ In practice f_{pu} is unlikely to materialize for unbonded tendon. The current discussion refers to a hypothetical upper-bound condition

¹⁶ The dimension of the wobble coefficient K includes the coefficient of friction. K is μ (average of unintended change in angle per unit length of tendon).

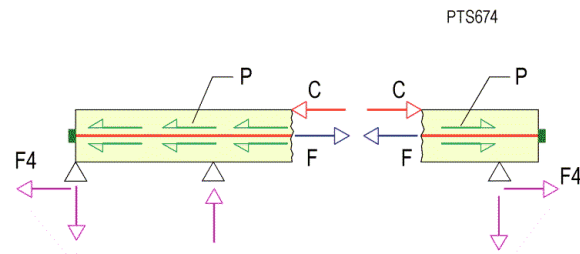

FIGURE R.1.2-4 Partial Free Body Diagram of a Non-Symmetrical Member Cracking

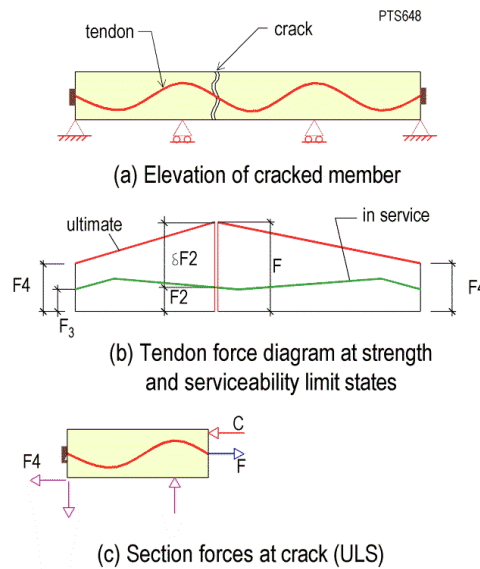

FIGURE R.1.2-5 Member with Unbonded Tendon; Tendon Force Diagram at Service and Ultimate Limit State

In the preceding diagram, the force $(F - F_4)$ is the force that will be available to resist applied moments – the moment capacity of the section. The force $(F - F_4)$ is the friction force between the strand and its sheathing.

From the preceding diagram, it is concluded that when members reinforced with unbonded tendons experience excessive support restraints, the friction between a tendon and its sheathing plays a role in the strength available from the tendon at the member's ultimate strength capacity. The larger the friction force between a tendon and its sheathing, the greater will be the available tendon strength to resist applied loads.

R.1.3 Bonded Tendons; Safety and Restraint Cracks

Members reinforced with bonded tendons develop a larger moment capacity at locations of restraint cracks compared to members that are reinforced with the same amount of unbonded post-tensioning. There are three reasons.

First, bonded tendons can typically develop their specified strength (f_{pu}) prior to failure, whereas members reinforced with unbonded tendons tend to undergo large deflections, and reach failure due to crushing of concrete or excessive deflection,

before tendons reach their specified strength (f_{pu}). Consequently, ACI 318¹⁷ [ACI 318, 2011] and EC2 [EC2, 2004] specify a significantly lower permissible stress (f_{ps}) for unbonded than bonded tendons for flexural capacity design of concrete members. Depending on the span dimensions for unbonded tendons, ACI 318 limits the increase in tendon stress at ultimate strength to between 30 to 60 ksi (206 to 413 MPa), whereas in EC2 the increase is limited to merely 100 MPa¹⁸ (15 ksi). This is about 7 to 9 % gain in strength over service condition, leaving about 30% of a tendon's strength untapped at member failure.

Second, for members reinforced with bonded tendons, the increase in demand moment at a point results in an increase in the tendon force at the same location. This local increase in tendon force is not compromised by the restraint of the supports. On the other hand, for unbonded tendons – as outlined in the previous sub-section – support restraints can diminish the effectiveness of local increase in tendon force in resisting an applied moment. This is explained in greater detail in what follows.

Third, compared to unbonded tendons, for bonded tendons the higher friction of between the strands and the sheathing at stressing works advantageously at the strength limit state of a cracked section.

Consider the member with a bonded tendon shown in Fig. R.1.3-1. Let the restraint from the supports be large enough to cause cracking as shown in part (a). The force in the tendon at the time of grouting follows essentially the friction diagram shown in part (b). Let the force in tendon at location of crack in service condition be F_2 . For the static equilibrium of the arrangement shown, F_2 is equal to the restraint of the support (F_3) while the gap at the crack is open. An increase in the applied moment at the crack location will tend to elongate the tendon locally leading to an increase in the tendon force to δF_2 (part c of the Figure).

The demand actions at the location of crack (part d of the Figure) are M and N , where from equilibrium of the forces N is equal to F_3 , the force due to restraint of the support¹⁹.

The tensile force available to resist the demand actions at the crack location is:

$$T = F_2 + \delta F_2 - F_3 \quad (\text{Exp R.1.1-14})$$

Since at location of crack $F_2 = F_3$, the available force (T) to resist the induced moment will be equal to δF_2 . Likewise from equilibrium of forces the compression force C is

$$C = (F_2 + \delta F_2) - F_3 = \delta F_2 \quad (\text{Exp R.1.1-15})$$

The moment that can be developed at the crack M is equal to:

$$M = Cz = \delta F_2 z \quad (\text{Exp R.1.1-16})$$

¹⁷ ACI 318-11 Section 18.7

¹⁸ EC2 Section 5.10.8(2)

¹⁹ Obviously, there will be a shear at the cut and the tendon will not be normal at the section, leading to both horizontal and vertical force components. These will change the numerical values, but they do not affect the concept being discussed. Hence, they are not included in order to keep the focus on the critical aspects of the concept.

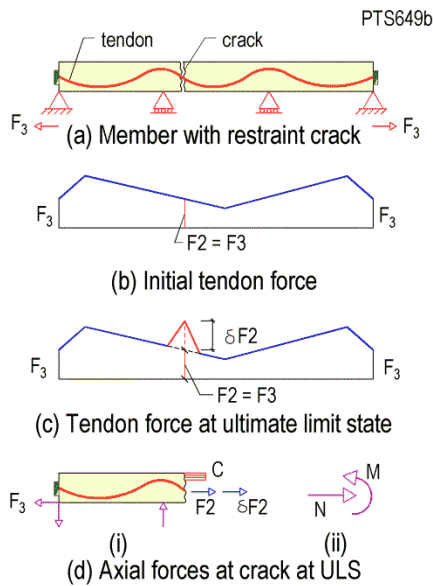

FIGURE R.1.3-1 Member with Bonded Tendon and Restraint Crack; Forces at Strength Limit

R.2 COMPARISON BETWEEN UNBONDED AND BONDED SYSTEMS

Figure R.2-1 compares the performance of a member reinforced with unbonded post-tensioning to a member with bonded post-tensioning. Referring to the figure, the net force (T) developed at the crack to resist a demand moment is²⁰:

$$\text{Unbonded: } T = F - F_4 \quad (\text{Exp R.1.2-1})$$

$$\text{Bonded: } T = F - F_3 = \delta F_2 \quad (\text{Exp R.1.2-2})$$

In summary, the available post-tensioning force T to resist an applied moment for the two systems is:

For unbonded:

$$T = F - F_4 \quad (\text{Exp R.1.2-3})$$

For bonded:

$$T = F - F_3 \quad (\text{Exp R.1.2-4})$$

²⁰ For ease of comparison the diagram shows the increase in tendon force at ultimate strength δF_2 to be the same for both bonded and unbonded. As a matter of fact, the increase in force for the unbonded system will be much less.

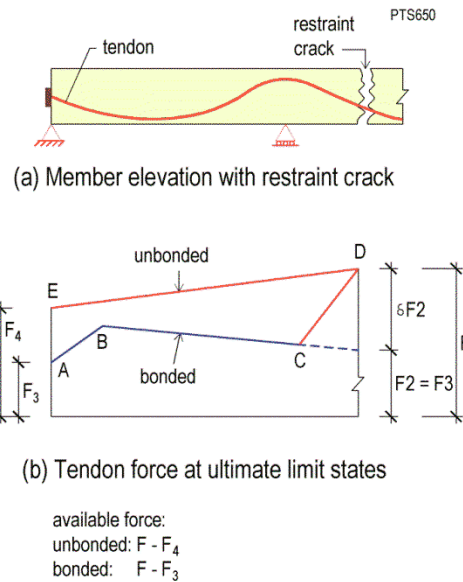

FIGURE R.2-1 Comparative Distribution of Force in Tendon at Ultimate Limit State for the bonded and unbonded post-tensioning systems

Q.6 REPAIR OF RESTRAINT CRACKS

Q.6.1 Crack Evaluation

The first step in addressing a restraint crack is to ensure that the crack has not compromised the floor's safety against overload, that is to say - the factor of safety at the strength limit state. Unlike conventionally reinforced concrete where the multitude of narrow and short cracks lead to an increase in deflection, the restraint cracks in post-tensioned floors typically do not cause a noticeable increase in the floor's deflection. If a floor's observed deflection is 15 to 20% more than the anticipated value for a similar panel without cracking, the crack's impact on the floor's structural safety should be evaluated before deciding on a repair scheme.

The next issue to review is whether the slab surfaces on either side of the crack are on the same plane. An offset between the two sides of a crack should be viewed as a sign of possible structural damage and should be investigated before repair. There is no clear rule regarding how much offset between the planes of the two sides can be tolerated. Opinions seem to favor a value not exceeding 1/16 – 3/32 in. (2 mm), but less than the width of the crack.

Q.6.2. Cracks to Repair

Cracks need not be repaired, if (i) they are not visible, or if visible are not objectionable; (ii) they do not impair the function of the floor; and (iii) they do not expose the member to elements of corrosion. Expansion joints in building construction, or the joint shown in Fig. Q.4.2.E-1 are in effect planned cracks at locations that do not impair the function and safety of the slab.

If there is the potential of exposure to corrosive elements, cracks that are wider than 0.1 in. (2.5 mm). should be repaired. This is in line with the allowable design criterion for members reinforced with unbonded tendons, where a crack width of 3 mm (0.12 in) is allowed by design²¹.

Q.6.3. Time of Repair

Restraint cracks will continue to form and widen two to three years after the tendons are stressed however the rate of crack formation and widening will decrease with time. Ideally, cracks should not be repaired until a year or two after construction. This may not be practical, however, as floors often must be placed in service soon after construction.

Q.6.4 . Method of Repair

Cracks that are working (opening and closing) such as those on the exposed surfaces of buildings that are subject to temperature variations are best repaired by routing a groove along the crack and filling the groove with a flexible sealant that is able to withstand the movement. Cracks that are continuing to widen but could expose the reinforcement to corrosive elements, or are causing objectionable leakage, should likewise be filled with flexible sealant, with the understanding that the repair may have to be redone once the crack has stopped widening. Cracks that are not expected to widen further and are not subject to movement are best repaired using a low viscosity epoxy to fill the gap.

Q.7 REFERENCES

Aalami, B. O. and Barth, F. G. (1988) “ *Restraint Cracks and Their Mitigation in Unbonded Post-Tensioned Building Structures,*” Post-Tensioning Institute, Phoenix, AZ, 49 pp.

AASHTO (1996), “Guide Specifications for Design and Construction of Segmental Concrete Bridges,” American Association of State Highway and Transportation Officials, Washington, DC, www.transportation.org, 1996.

ACI 209, (1992), “Prediction of Creep, Shrinkage and Temperature Effects in Concrete,” American Concrete Institute, Farmington Hills, MI 48331

Collin, M. P., and Mitchel, D., (1997), “Prestressed Concrete Structures,” Response Publications, Canada, pp. 766, (1997)

EC2 – 1992-1-1:2004, (2004) “Eurocode 2: Design of Concrete Structures, Part 1-1: General rules and rules for buildings,” European Committee for Standardization, CEN, Brussels.

Q.8 NOTATIONS

To be complete

A = cross sectional area of concrete associated with tributary of prestressing force P , in², mm²;

a = total shortening of a member, in, mm;

²¹ EC2 bijan book

- CR = contribution of creep strain to shortening (Non-Dimensional ND);
- CR_0 = base creep coefficient, ND;
- CR_C = creep coefficient, ND;
- d = change in length of a member;
- E_c = modulus of elasticity of concrete on day 28, psi, MPa;
- E_{ci} = modulus of elasticity of concrete on day of stressing, psi, MPa;
- ES = total strain due to average elastic shortening;
- f'_c = 28 day concrete cylinder strength, psi, MPa;
- f'_{ci} = concrete cylinder strength on day of stressing, day t, psi, MPa;
- $f_{cm}(t)$ = mean concrete compressive strength at an age of t days;
- k_c = volume to surface correction factor for CR_0 , ND;
- k_{cRH} = correction factor for CR_0 for ambient relative humidity, ND;
- k_f = correction factor for CR_0 for concrete strength, ND;
- $k(PT)$ = correction factor for CR_0 for the average precompression from post-tensioning, ND;
- $k_{v/s}$ = correction factor for base shrinkage for volume to surface ration (V/S), ND;
- L = total length of a member, ft, m;
- P = prestressing force; lb, kN;
- S = exposed surface area of a typical unit length of concrete member, in², mm²;
- SH = contribution of shrinkage strain to shortening (Non-Dimensional ND);
- s = a coefficient which depends on the type of cement, ND;
- t = age of concrete in days;
- T = change in temperature, C⁰, F⁰;
- V = concrete volume of a typical unit length of concrete member, in³, mm³;
- W = unit weight of concrete, pcf, kg/m³;
- α = coefficient of thermal expansion. / C⁰, /F⁰;